

A-2085-04: 4 Degree-of-Freedom Arm

A fully integrated collaborative manipulation platform.



X-Series Actuators *Default Configuration*	HEBI Mounting Brackets and Wiring Included 1x X5-1 (Wrists) 2x X5-4 (Base and Elbow) 1x X5-9 (Shoulder)
Add-on Accessories	1x Gas Spring (↑ Payload, ↓ Workspace) 1x HEBI Gripper Assembly
Mechanical Interface	T-Slot Extrusion (80/20®) Easy integration of additional components or sensors
Software	Joystick Control with the HEBI Mobile I/O App (iOS & Android) Example code in MATLAB, C, Python, and ROS

Weight	2.5 kg
Max Reach	650 mm
Payload* @ Max Reach	0.5 kg
Half Reach	325 mm
Payload* @ Half Reach	1.5 kg
Gripper Max Finger Torque (X5-9)	1.1 Nm
Gripper Max Finger Force (50mm from Pivot)	23 N
Parallel Gripper Stroke Length	82 mm
Payload calculated using default arm configuration without a gas spring Arm and Gripper configuration are customizable upon request.	

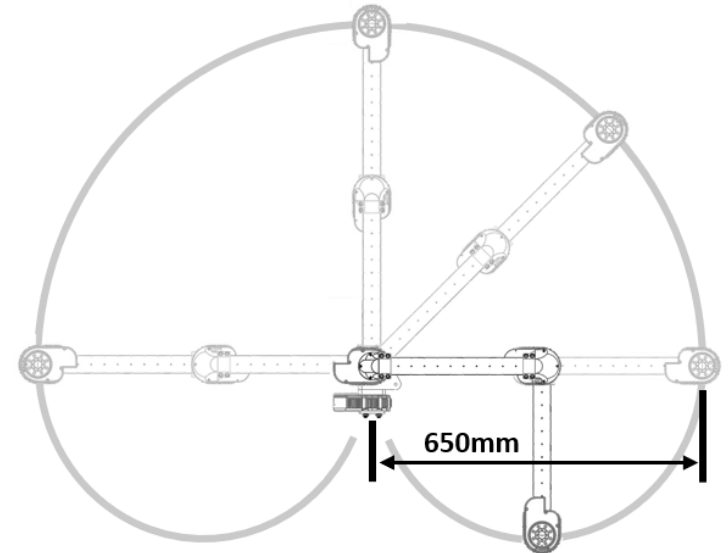

Request a quote at www.hebirobotics.com