

HEBI ROBOTICS

Igor

Meet Igor - HEBI's wheeled, self-balancing, R/C robot kit with 14 degrees of freedom.



Size	Height: ~1.00 m	Arm Span: ~1.50 m
Weight	17.5 kg (with two batteries)	
Linear Speed	1.0 meters per second	
Batteries	Grin Technologies, LiGo Battery (Fits 2) 36V 2.7Ah, 98Watt*Hrs, 10A Max	
Battery Life (Using 2 Batteries)	1-2 Hours Ability to hot-swap batteries for uninterrupted use	
X-Series Actuators	HEBI Mounting Brackets and Wiring Included 4x X5-4 (Bases and Elbows) 4x X5-9 (Shoulders and Hips) 2x X5-1 (Wrists)	
Accessories	2x Paddle Grippers	2x Gas Springs 2x 8" Wheels
Mechanical Interface	T-Slot Extrusion (80/20®) Easy integration of additional components or sensors	
Integrated Electronics	Intel® NUC Computer Ethernet Switch	Wireless Access Point Power Electronics
Bulkhead Connectors	1x HDMI to Computer Open Ethernet Port on Hip Actuator Anderson Powerpole connectors for Batteries Additional Power Outputs 5V, 12V, and 24V (5A Each) Computer (White LED) and Actuator (Blue LED) Power Buttons	4x USB to Computer M-Stop Button
Software	Joystick Control with HEBI Mobile I/O App (iOS and Android) Example code available in MATLAB and Python (Preinstalled)	

Request a quote at www.hebirobotics.com

HEBI Robotics | 91 43rd Street, Suite 200, Pittsburgh, PA 15201

hebirobotics.com | info@hebirobotics.com

Robot Workspace

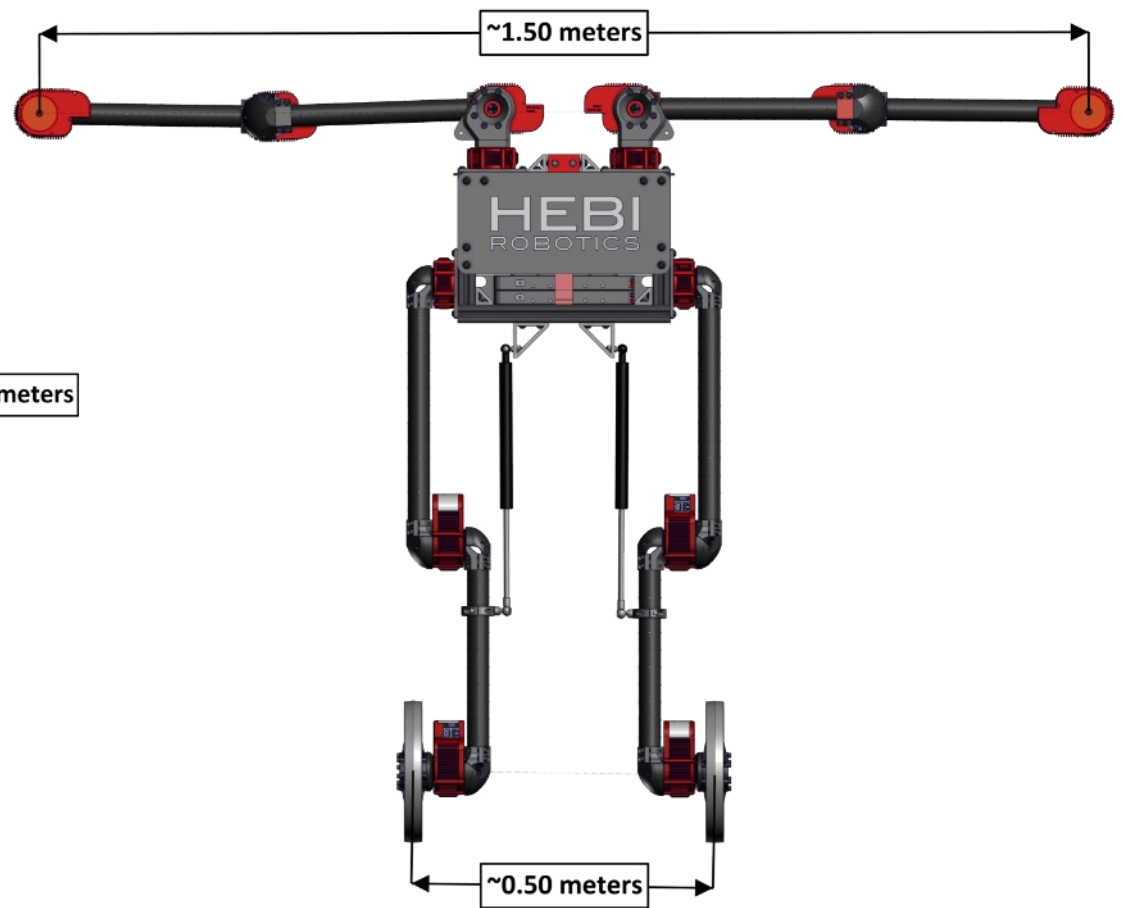
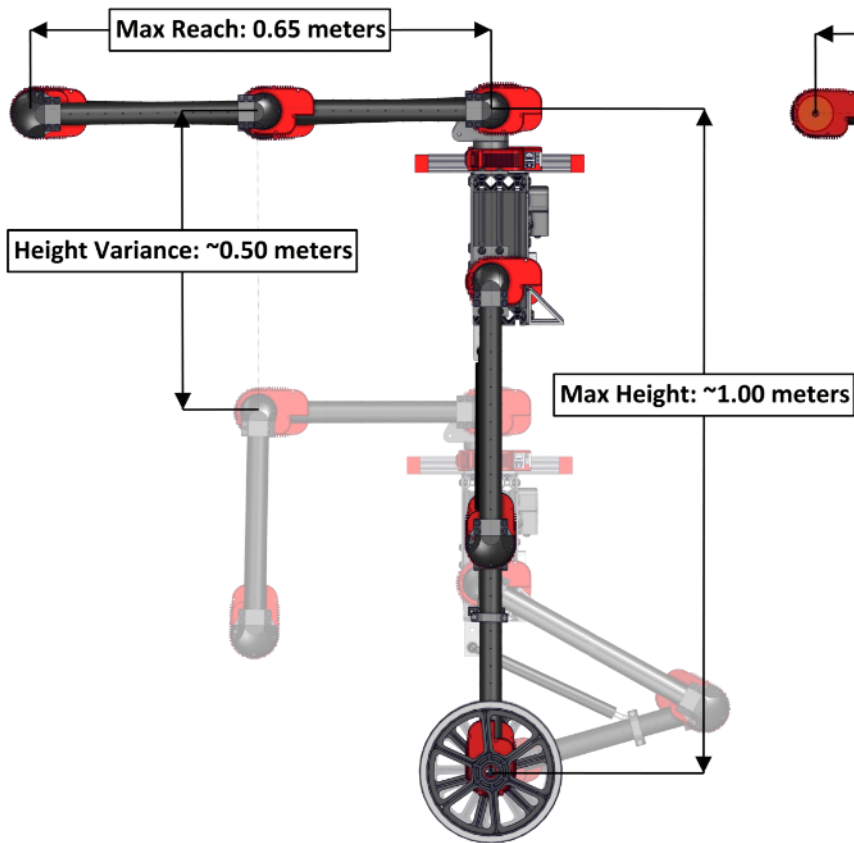

Optional Add-on:

Webcam and Tilt DoF

- Additional X5-4 Actuator
 - Logitech Webcam
- Set of Custom Mounting Brackets

