

Technical Specifications

Specifications	Value
Weight	5.60 kg
Reach	750 mm
Payload at Max Reach*	0.60 kg
Payload at Half Reach*	3.50 kg

Calculated using Default Configuration with Gas Spring.
Using a different configuration of T-Series Actuators will provide different payload capacities.

Movement	Working Range	Speed
Axis 1 – Base [Default: T8-9]	Continuous (limited by wiring)	180°/s
Axis 2 – Shoulder [Default: T8-16]	0° to +70° (limited by gas spring)	90°/s
Axis 3 – Elbow [Default: T8-9]	-155° to +155° (avoid end effector collisions)	180°/s
Axis 4 – Wrist 1 [Default: T5-1]	Continuous (avoid end effector collisions)	540°/s
Axis 5 – Wrist 2 [Default: T5-1]	Continuous (limited by wiring)	540°/s
Axis 6 – Wrist 3 [Default: T5-1]	Continuous (limited by wiring)	540°/s

Side View

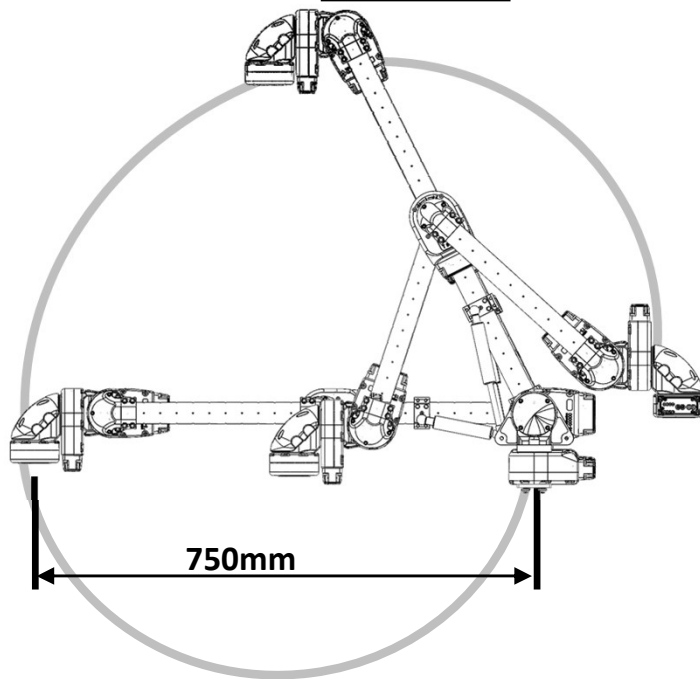

Top View

