



# T-Series 4-DoF Arm Kit

Assembly Instructions

# General Warnings and Cautions

## **Danger (May cause serious injury or death)**

- Keep water, flammables, solvents and other liquids clear from actuator.
- Keep fingers away from moving parts during operation.
- Cut power immediately if actuator emits strange odors or smoke.
- Keep actuator out of reach of children.

## **Warning (May cause injury or damage to actuator)**

- Do not expose the actuator to permanent and strong magnetic fields.
- Do not force screws into the bottom of the actuator. R8 = 8mm Tap Depth
- Use provided hardware with accessories and hand tighten as needed.
- Attempts to disassemble actuator will void the warranty and may cause permanent damage.

For more information please visit: [\*\*\*docs.hebi.us\*\*\*](https://docs.hebi.us)

# Technical Specifications

Specifications	Value
Weight	3.50 kg
Reach	650 mm
Payload at Max Reach*	1.00 kg
Payload at Half Reach*	5.00 kg

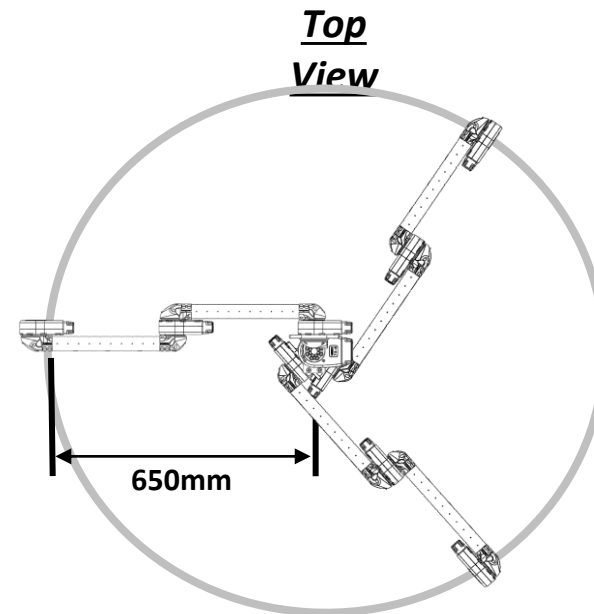
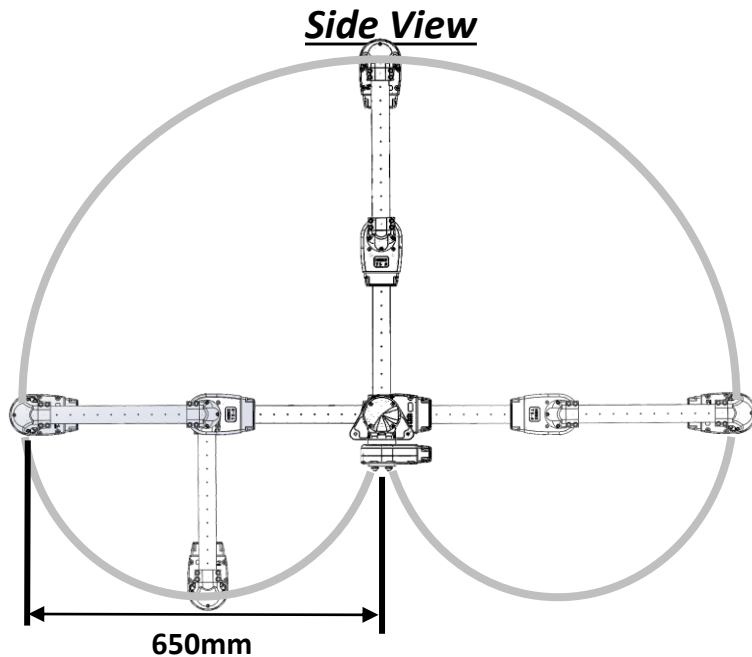

\*Calculated using Default Configuration with Gas Spring.\*  
Using a different configuration of T-Series Actuators will provide different payload capacities.

Movement	Working Range	Speed
Axis 1 – Base [Default: T5-4]	Continuous (limited by wiring)	180°/s
Axis 2 – Shoulder [Default: T5-9]	0° to +180°	90°/s
Axis 3 – Elbow [Default: T5-4]	-155° to +155° (avoid end effector collisions)	180°/s
Axis 4 – Wrist 1 [Default: T5-1]	Continuous (avoid end effector collisions)	540°/s

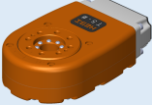
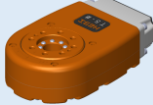
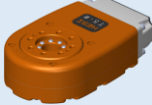
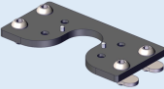
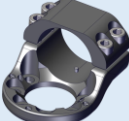
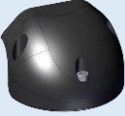
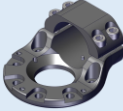
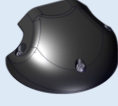
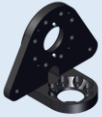

# Bill of Materials – Mechanical\*

**Default Configuration**

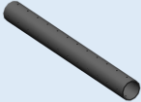
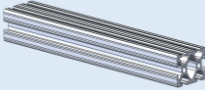
				
1 x T5-1	2 x T5-4	1 x T5-9		
				
1 x A-2228-01	2 x A-2218-01	2 x A-2090-02	2 x A-2219-01	2 x A-2231-01
				
1 x A-2221-01	1 x A-2232-01	2 x PM-2200-02 [300mm]	1 x PP-2141-12 (optional)	

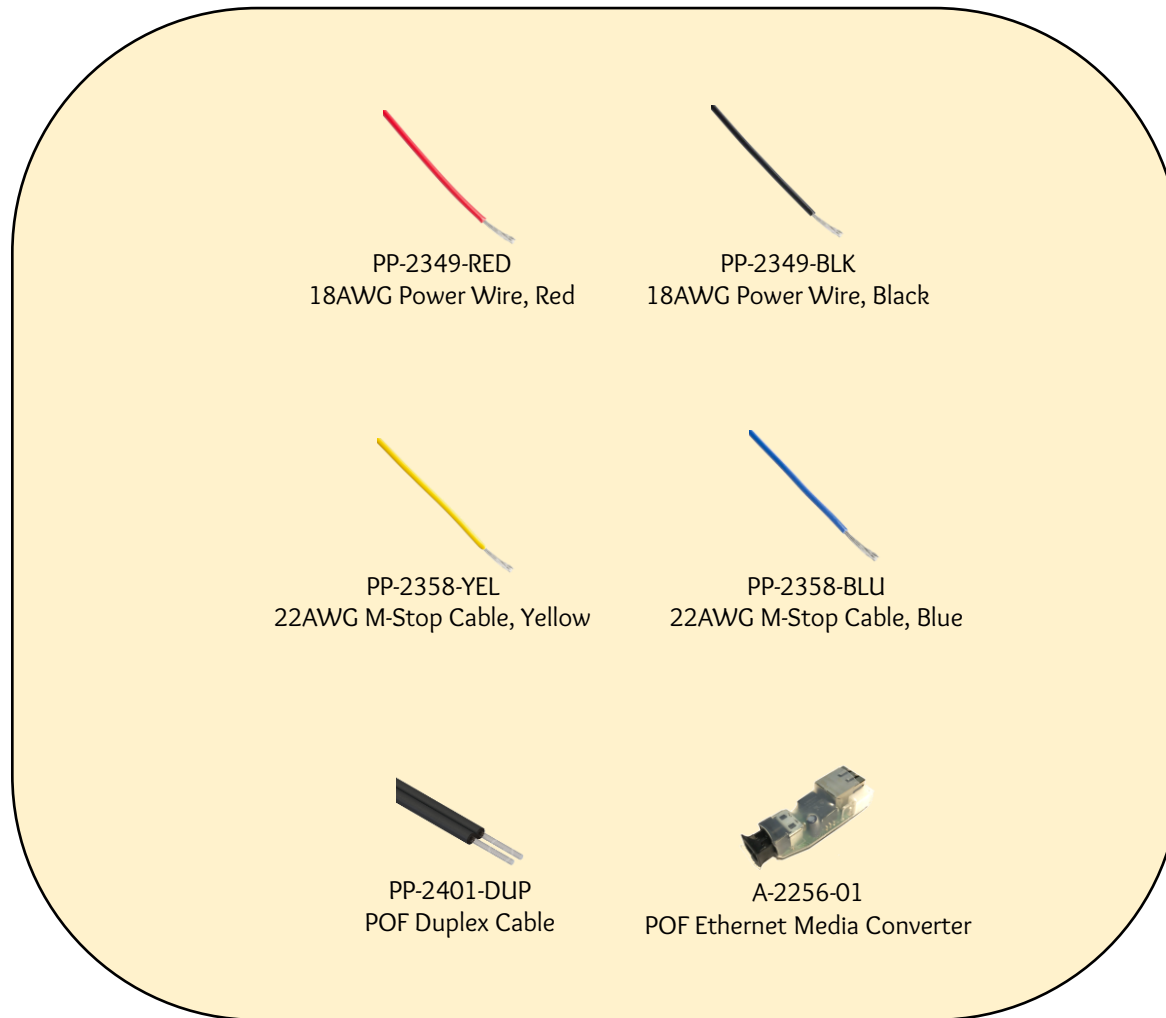

\*fasteners included, not shown\*

## Bill of Materials - Electrical

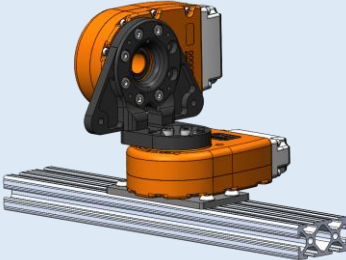

\*all items are included in T-Series Connection Toolbox\*

## Table of Contents

<u>Assembly</u>	<u>Image</u>	<u>Pages</u>
Tubes		[7]
Base		[8-12]
Final		[13-20]

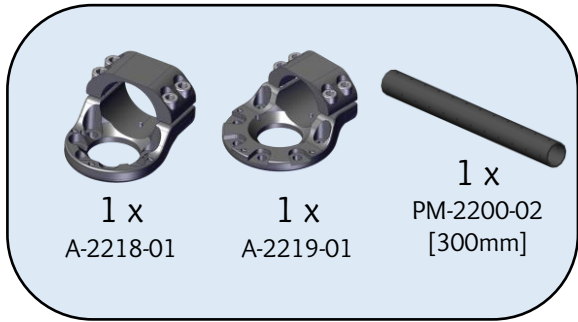
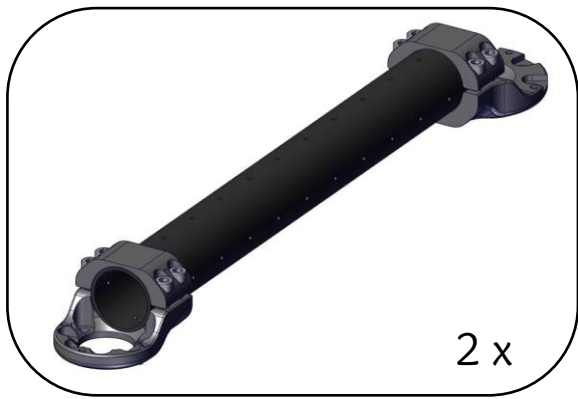

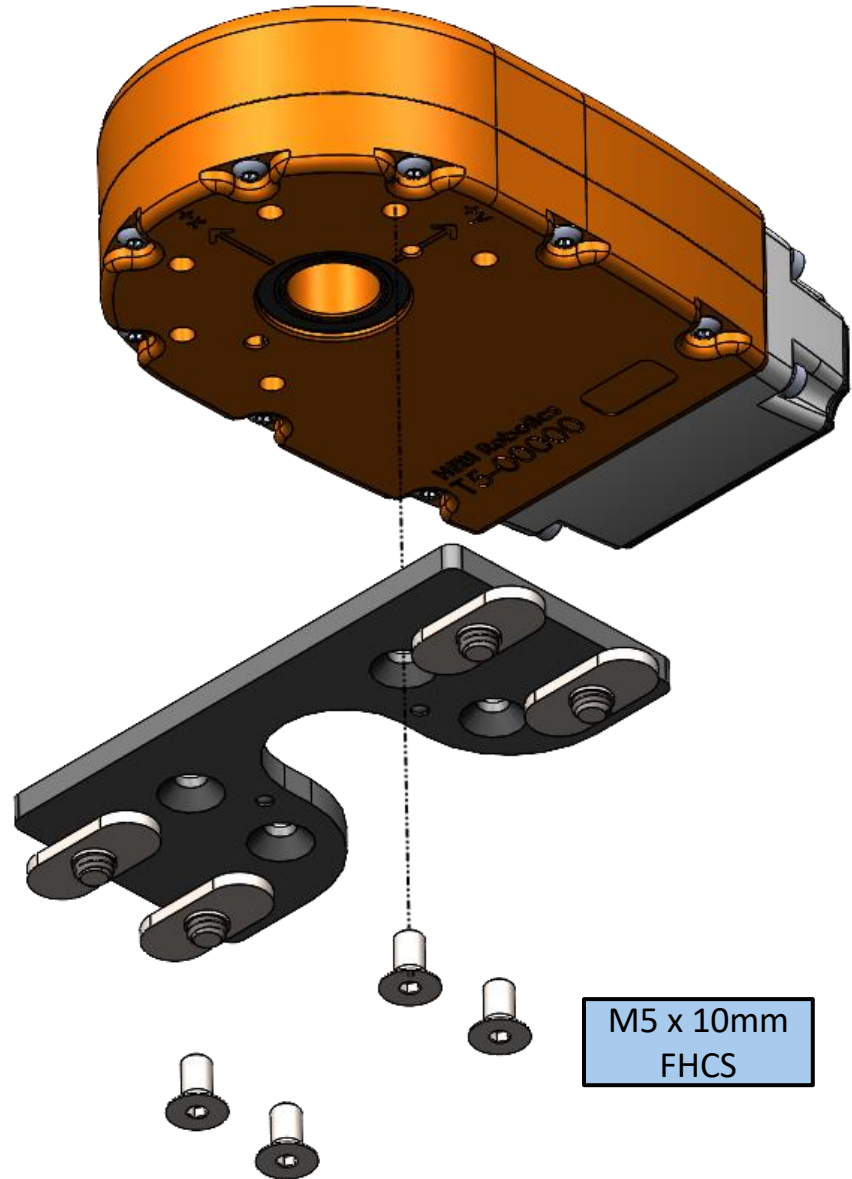
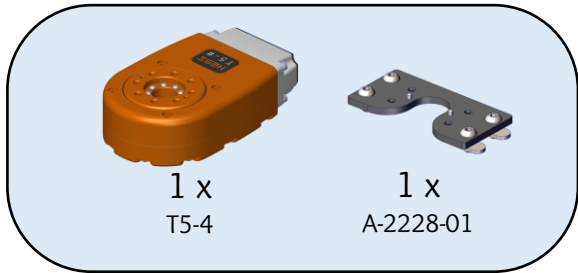
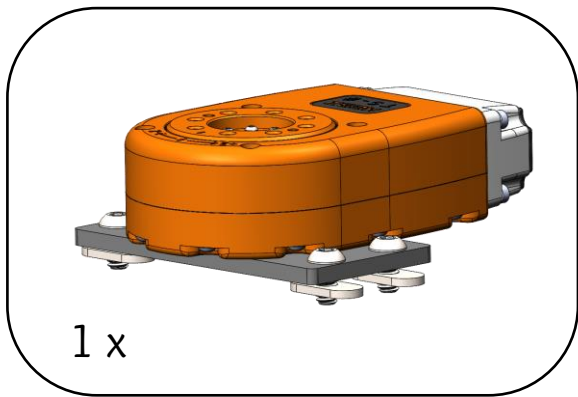



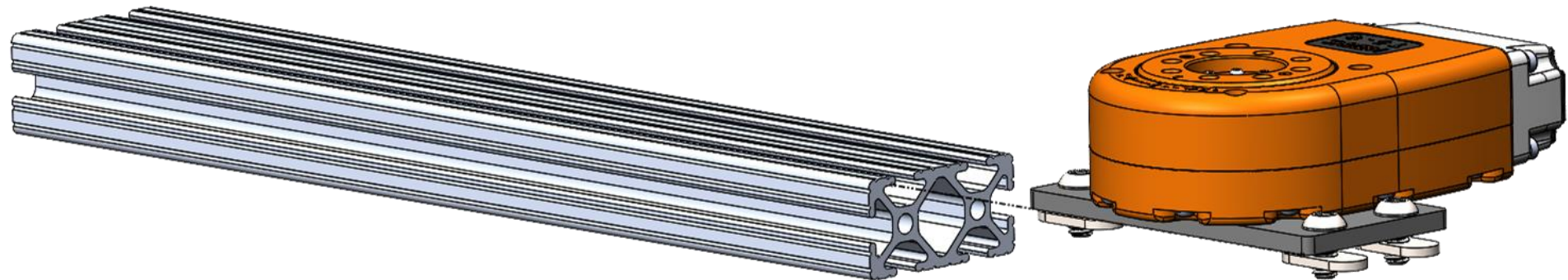
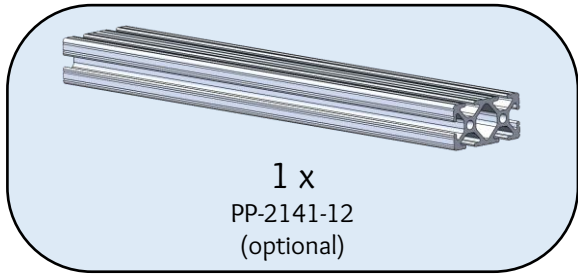
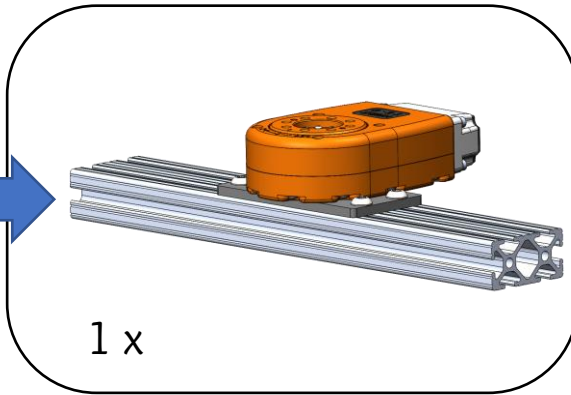
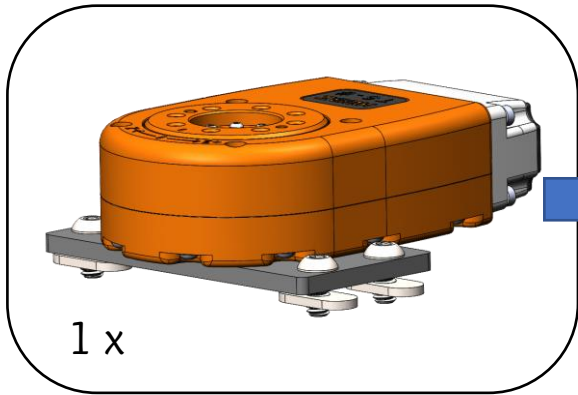

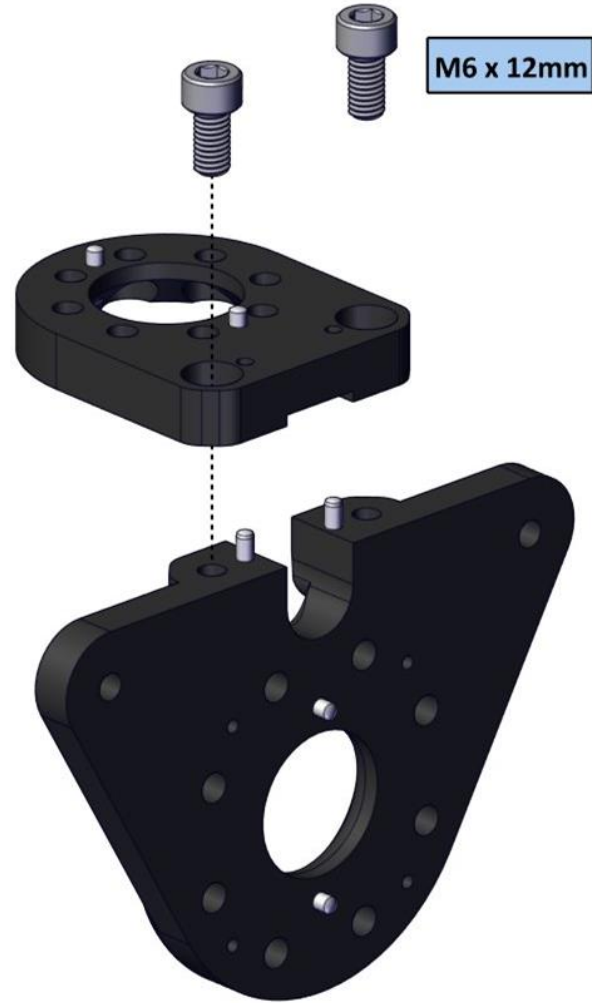
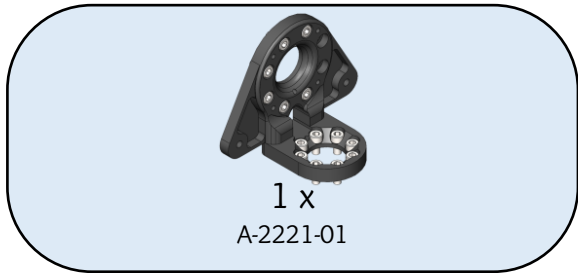
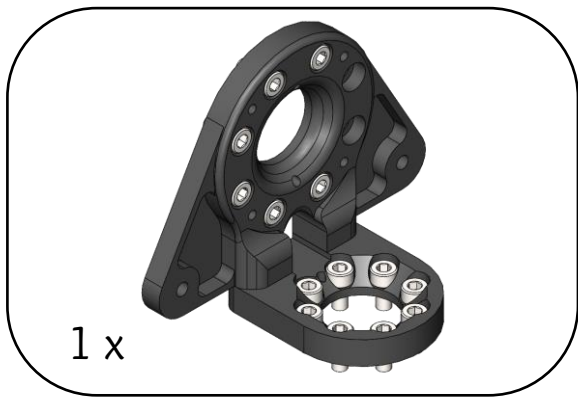

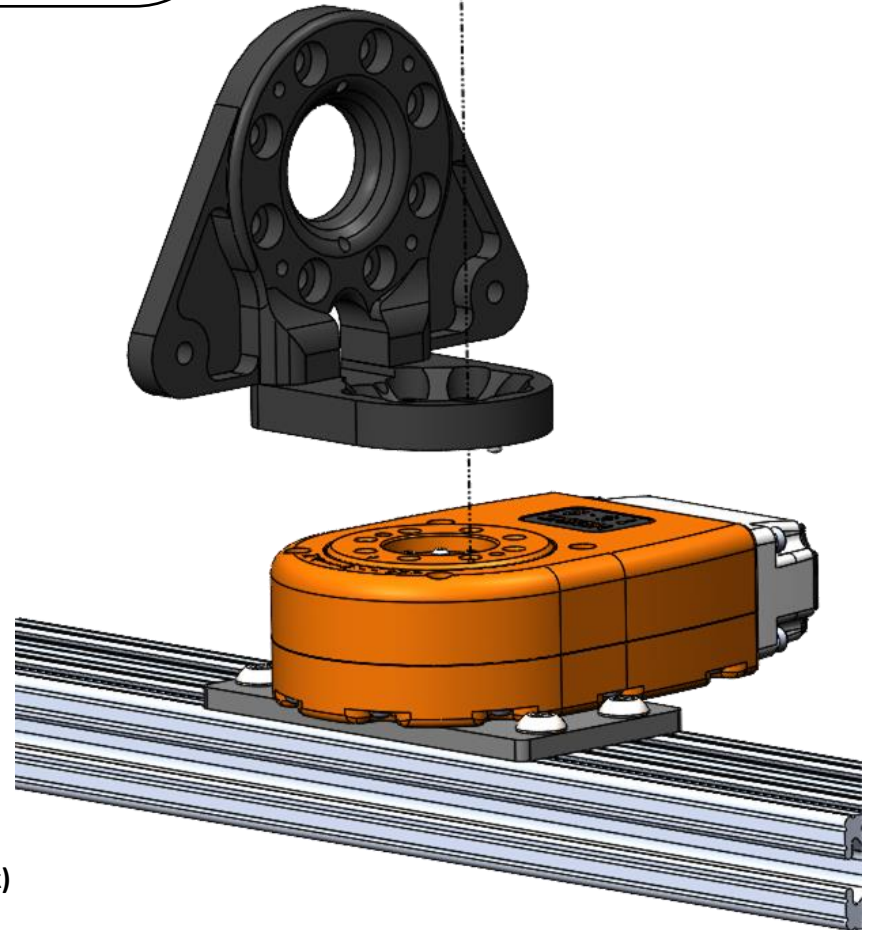
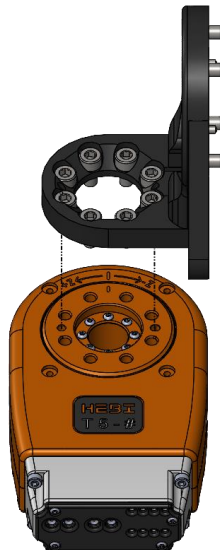
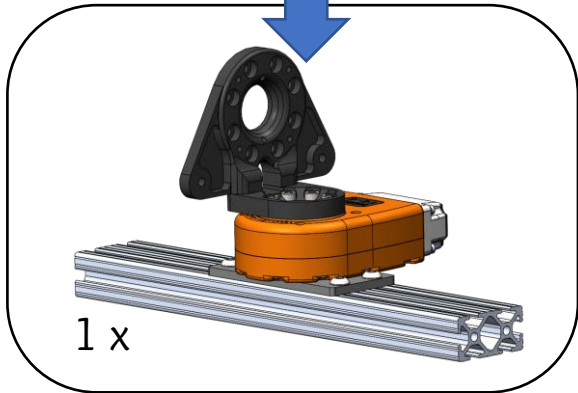
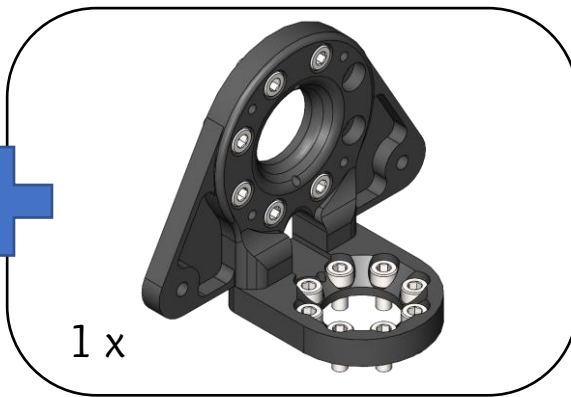
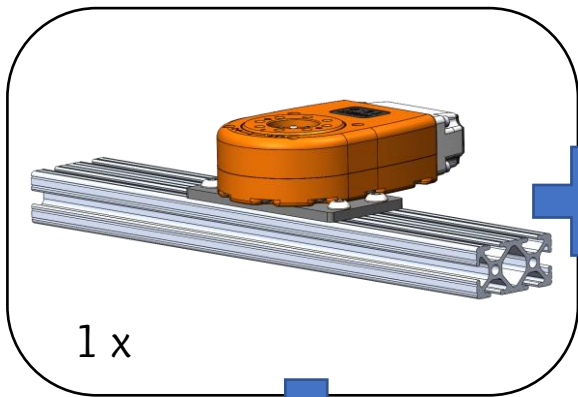

**Flat face towards outside**



 **Align with actuator  
output hub tick mark  
(Flat face parallel with tick mark)**

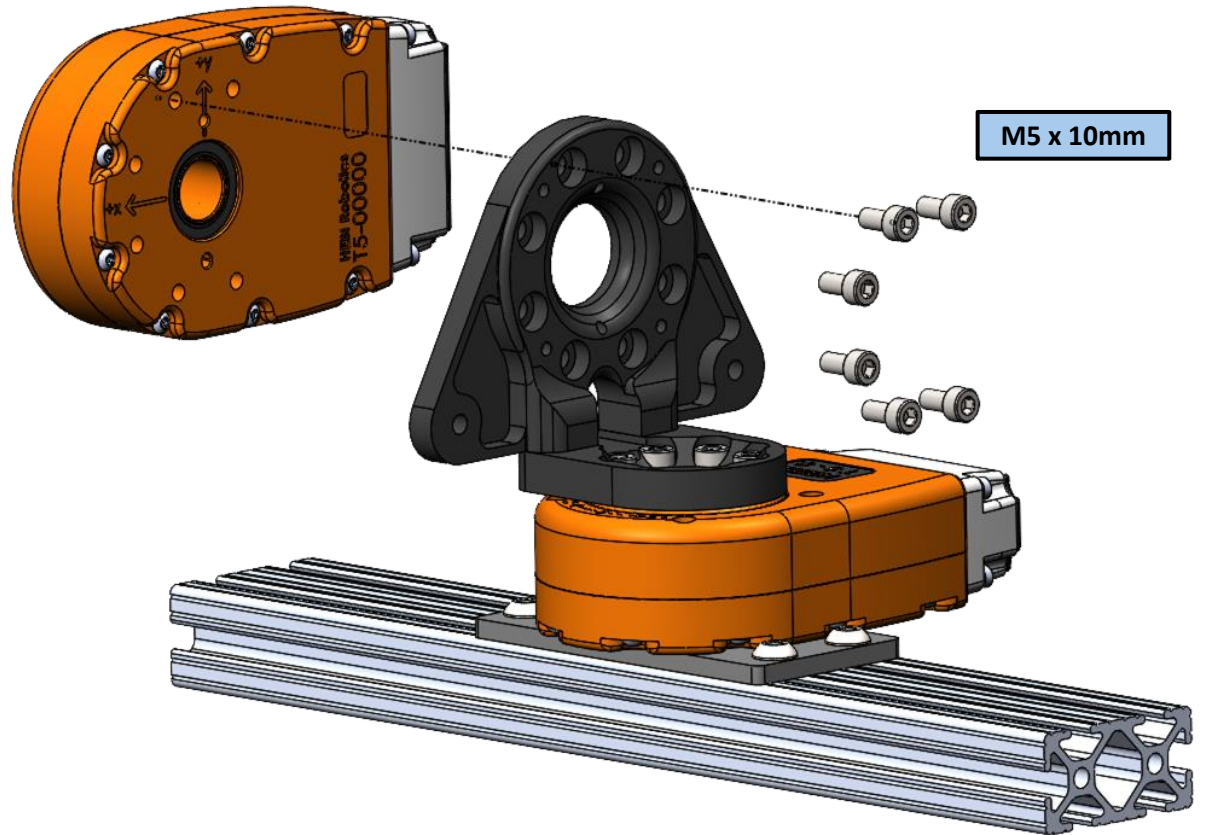
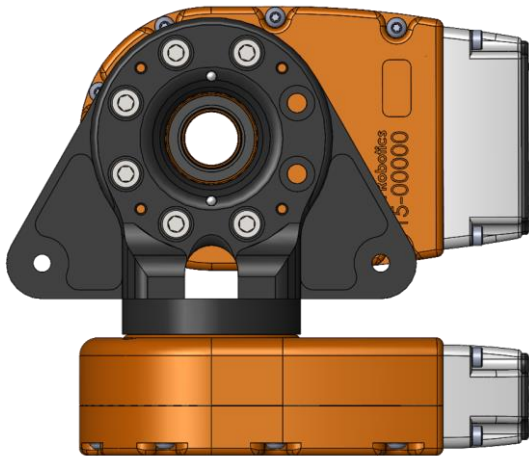
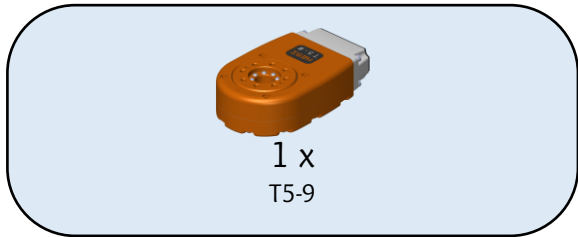
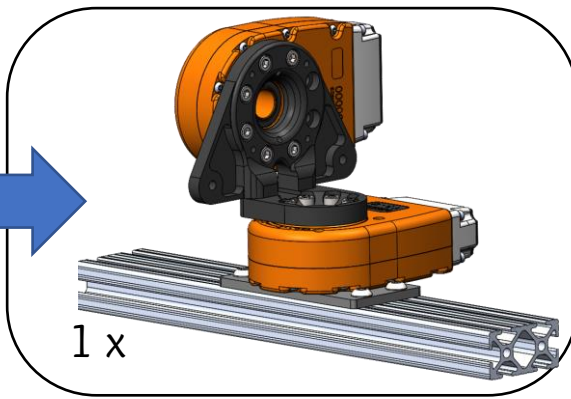
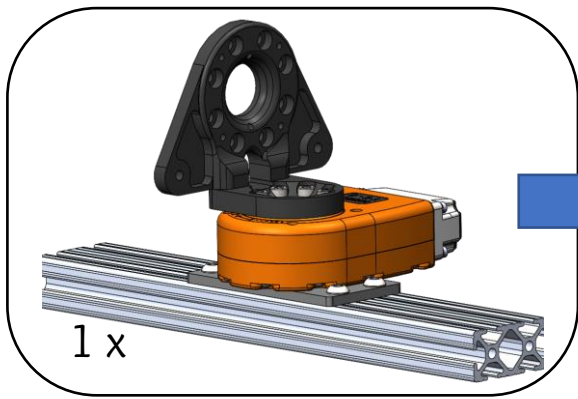

 **Connectors of both modules point the same way**

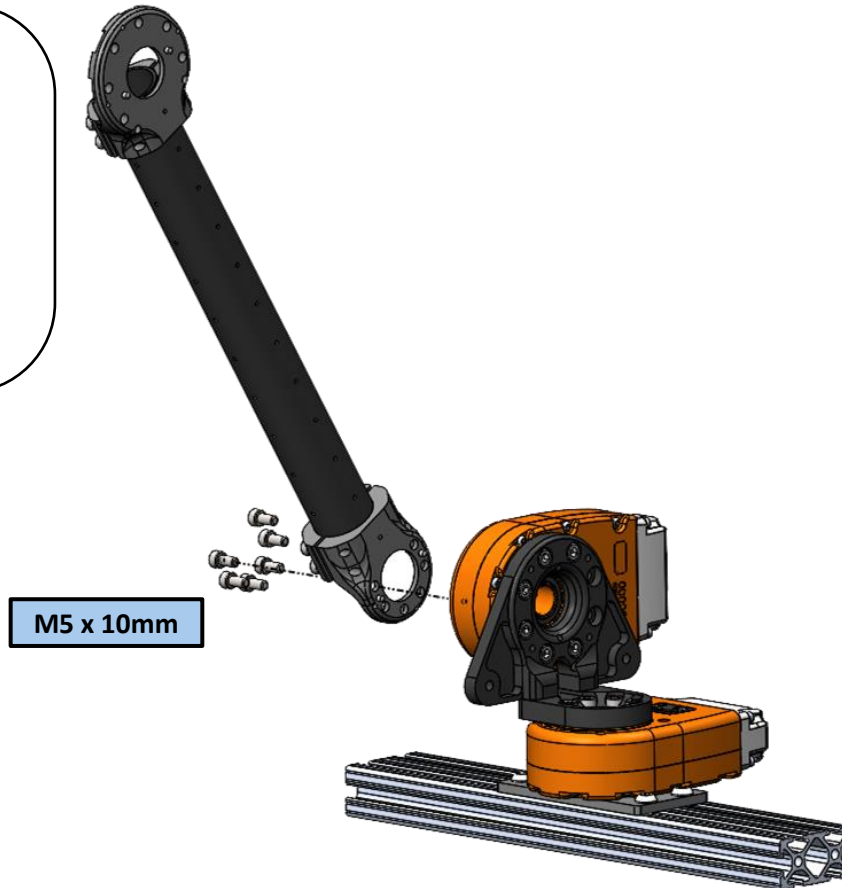
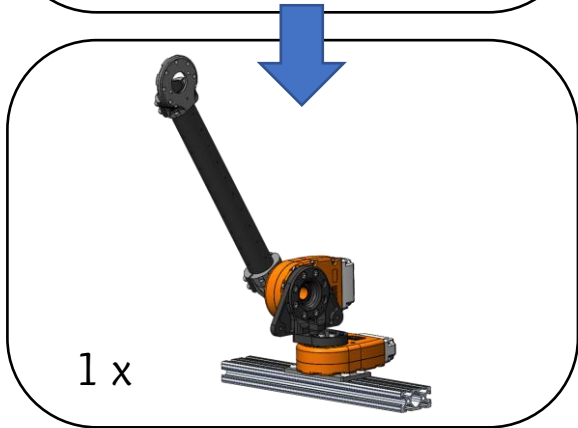
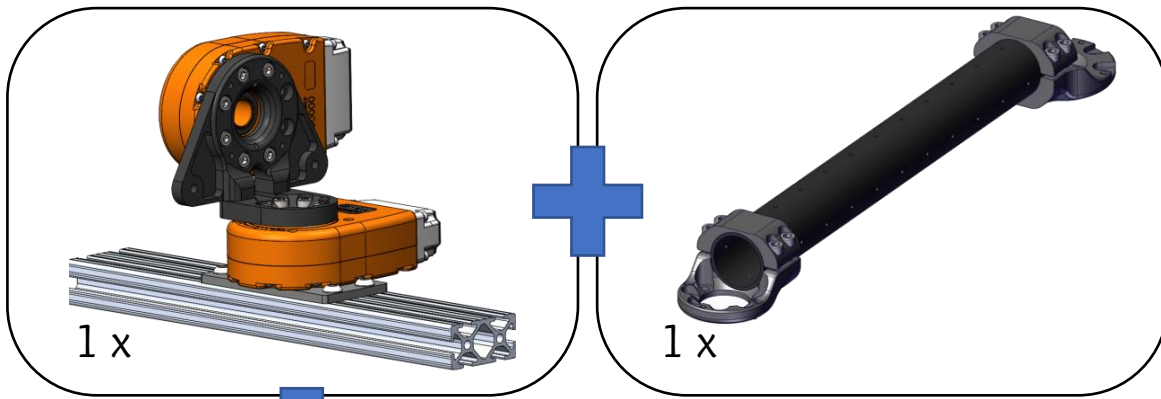

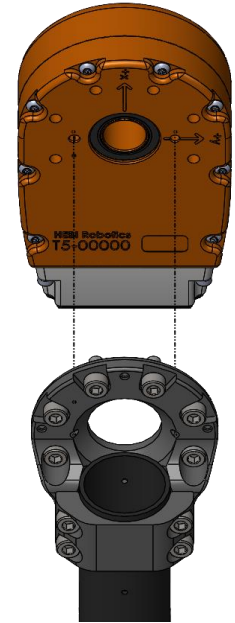
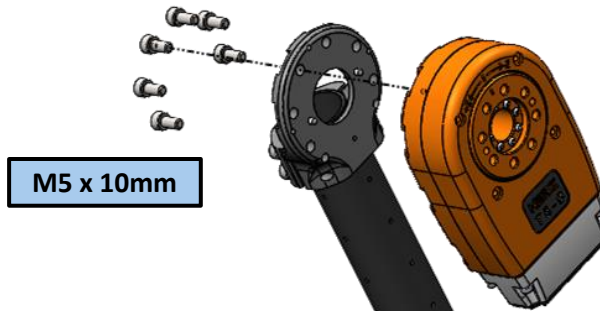
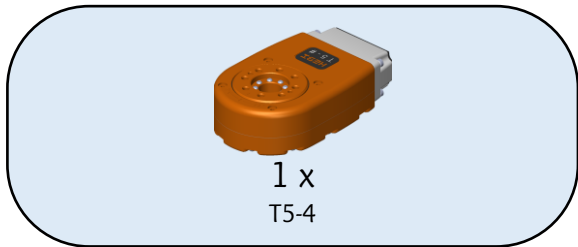
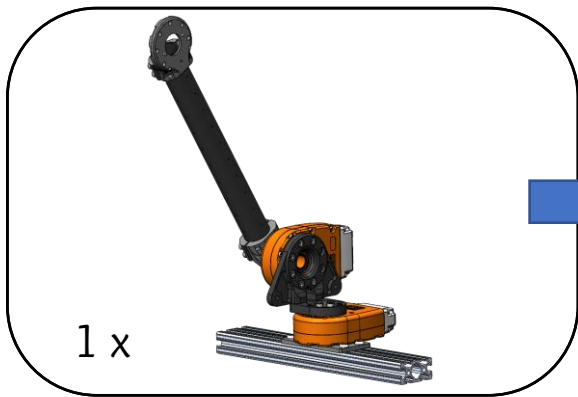

Align actuator connectors with tube

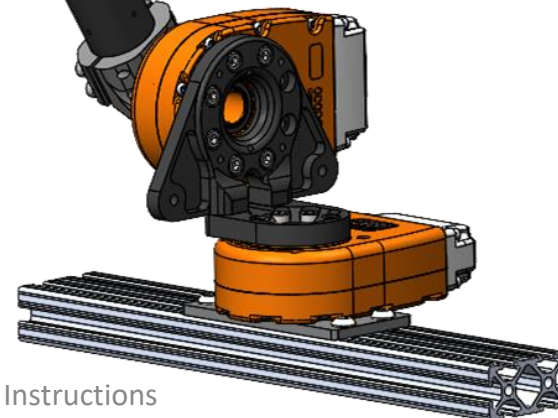

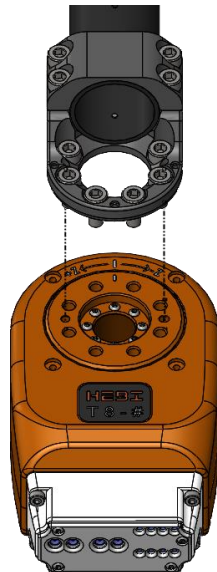
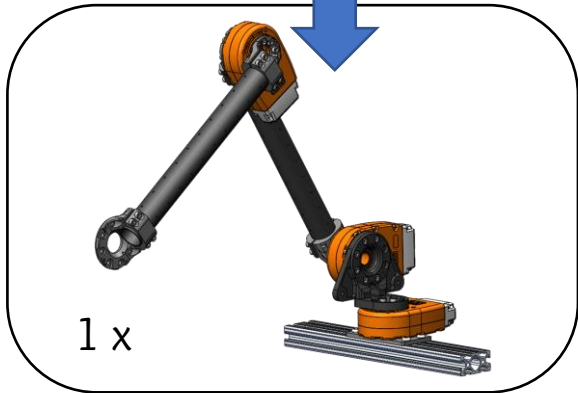
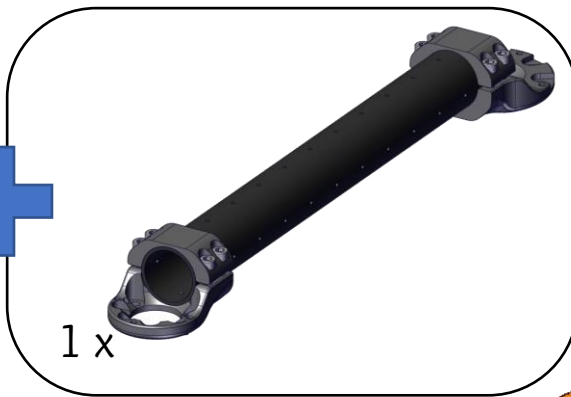

**Align with actuator  
output hub tick mark**  
(Tube aligns with tick mark)

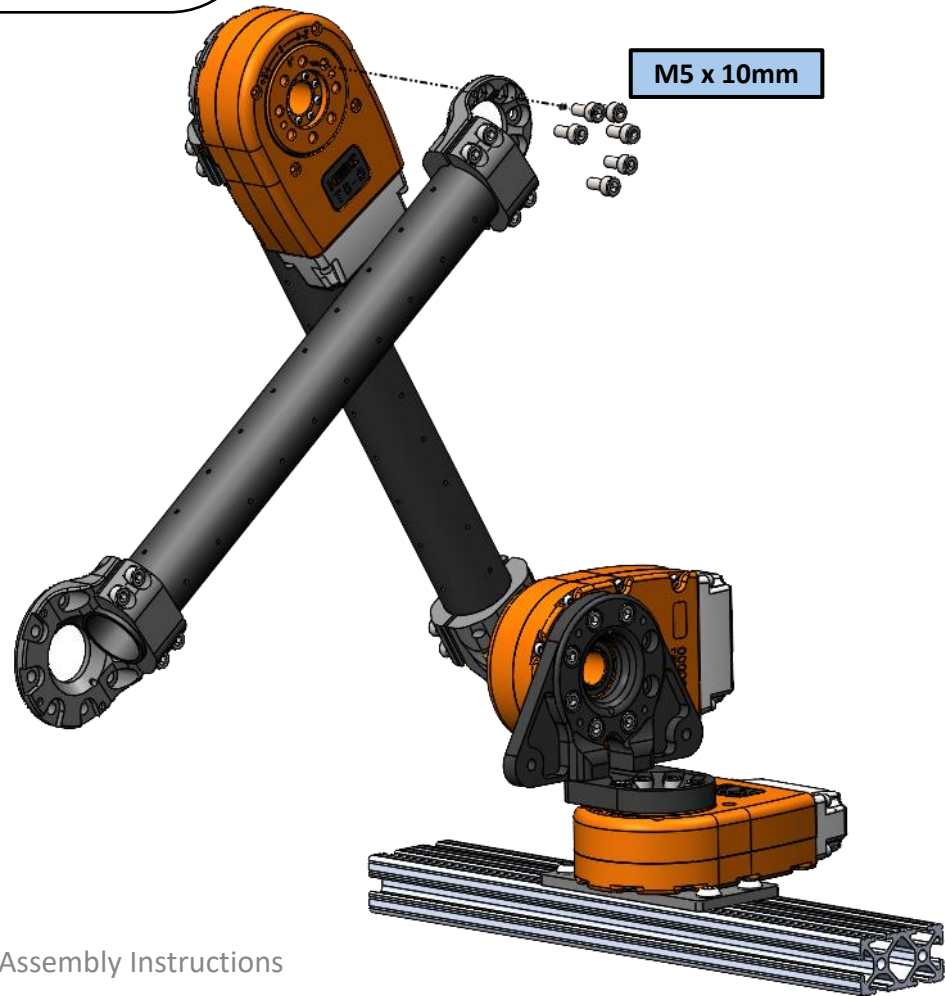

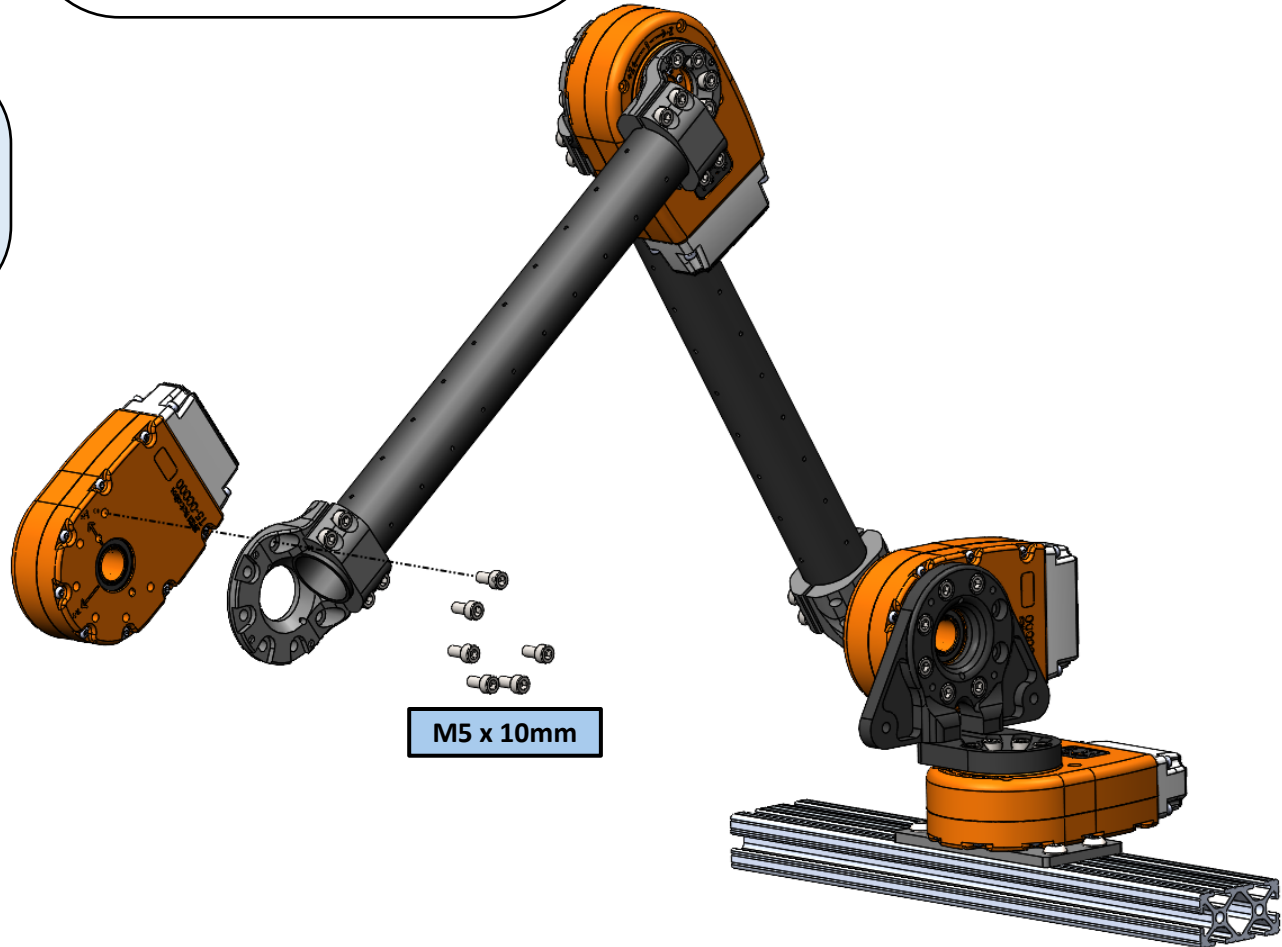
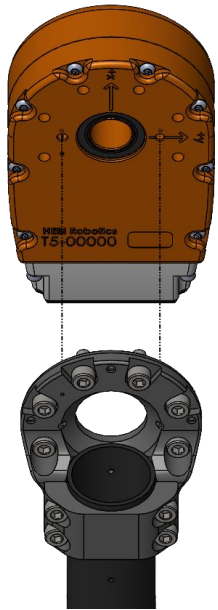
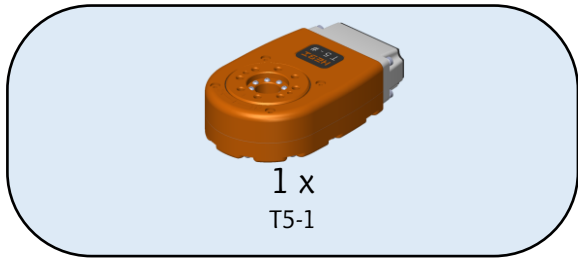

**Align actuator  
connectors with tube**



## Wiring Notes

- Keeping wires organized will help prevent tangling and add a nice aesthetic.
  - Spiral sleeving is a good accessory for organizing loose wires
- Visit the following link to see detailed instruction on connecting wires to T-Series Modules.

<http://docs.hebi.us/#r-series-quickstart>

For more information visit: [docs.hebi.us](http://docs.hebi.us)



[Spiral sleeving]

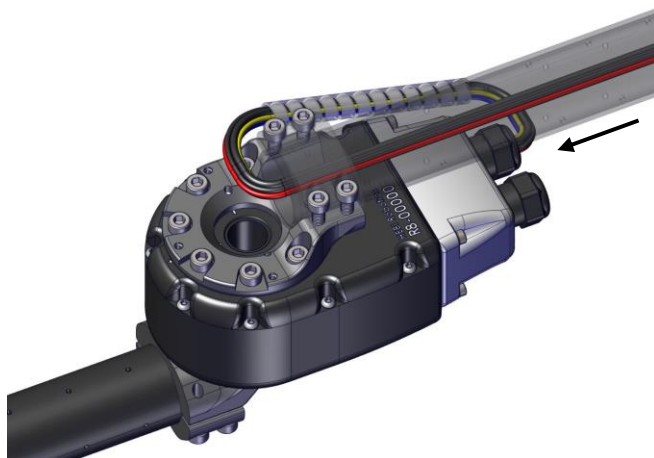

Wires that come from the previous joint should be inserted directly to actuator ports.

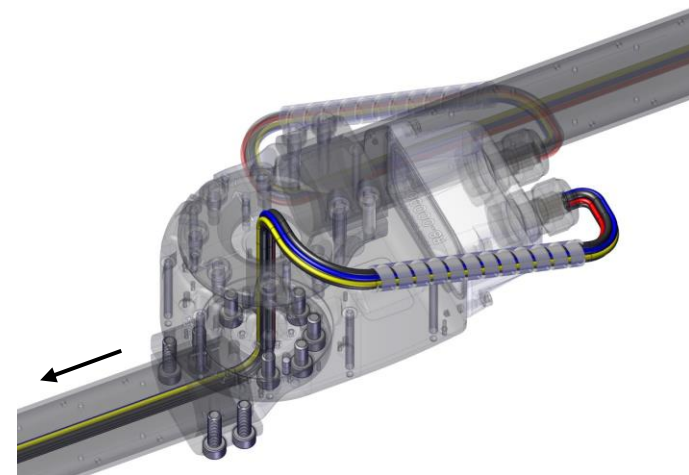

Wires that connect to the next joint should be threaded through the actuator's bore hole.

# Wiring Example

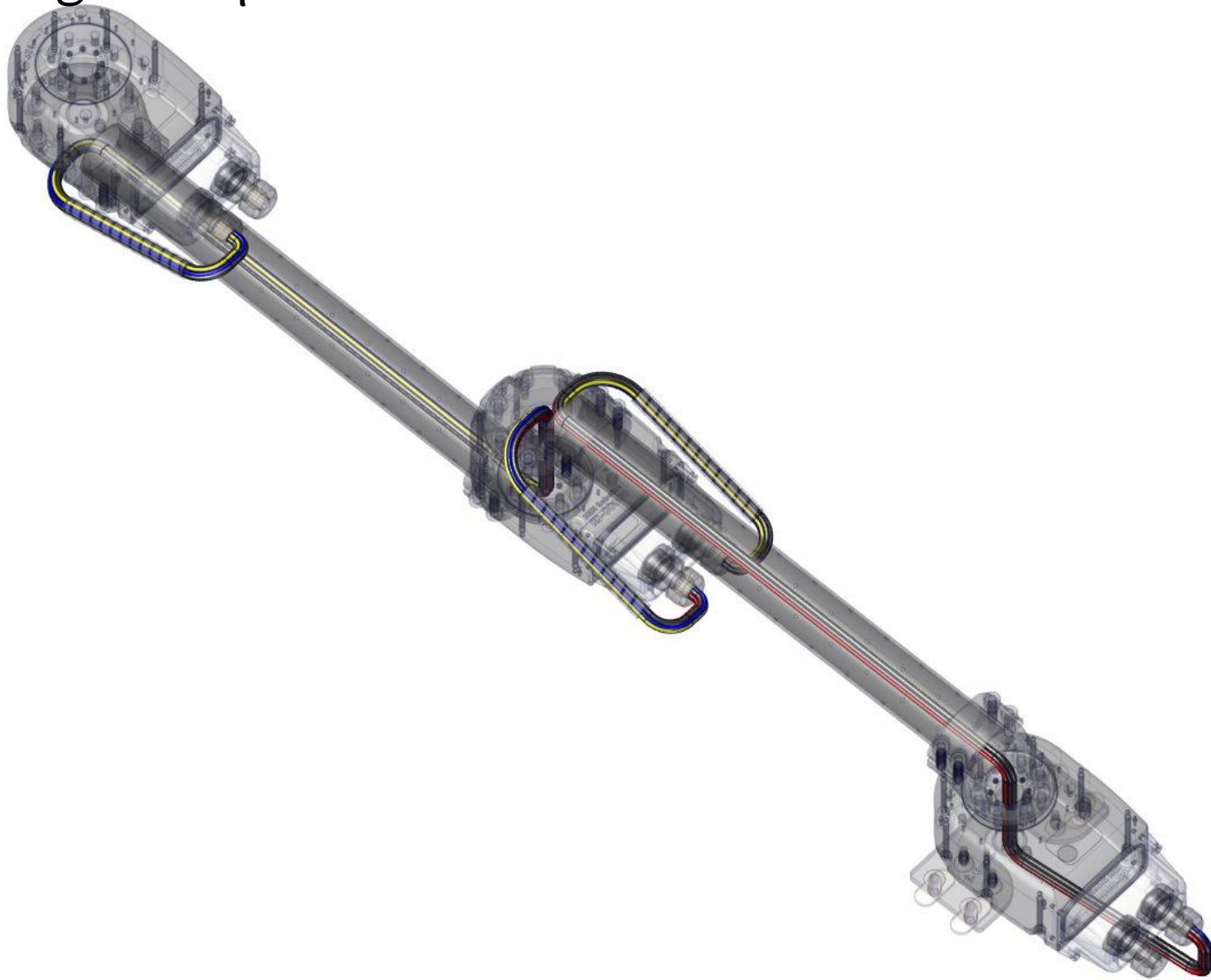

## Wiring Diagram with Gripper

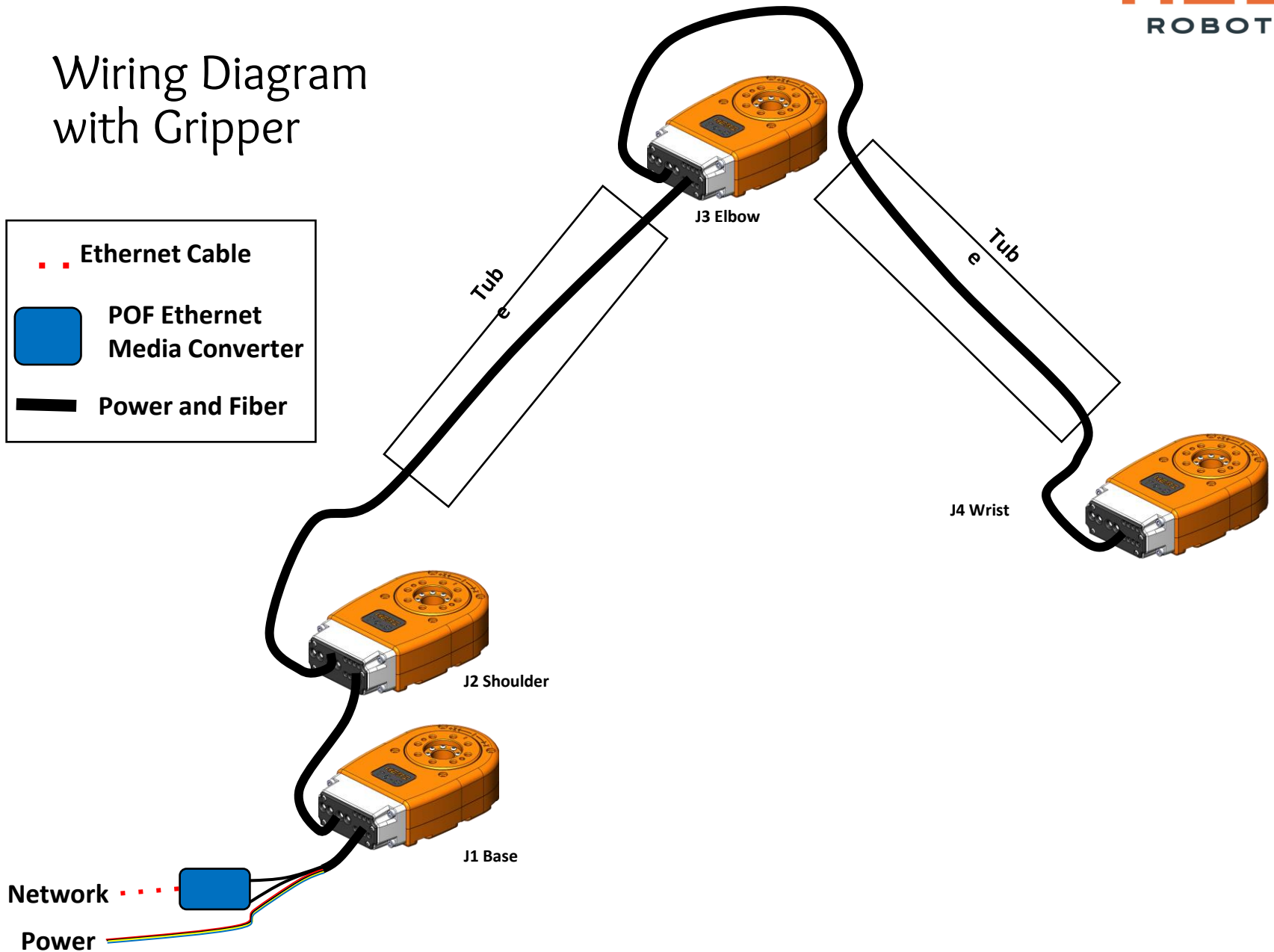
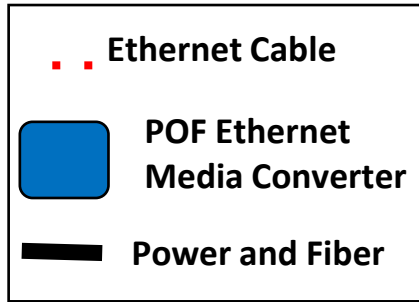

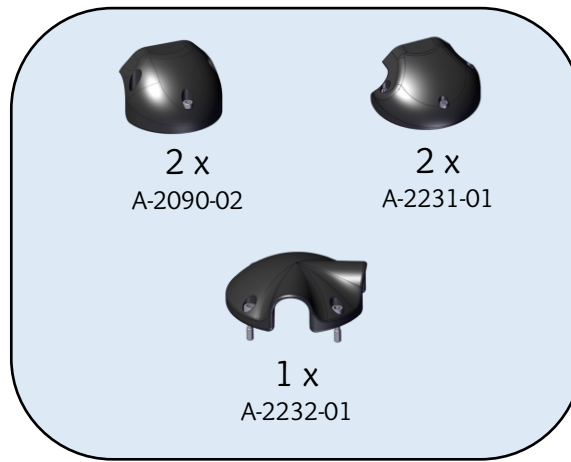
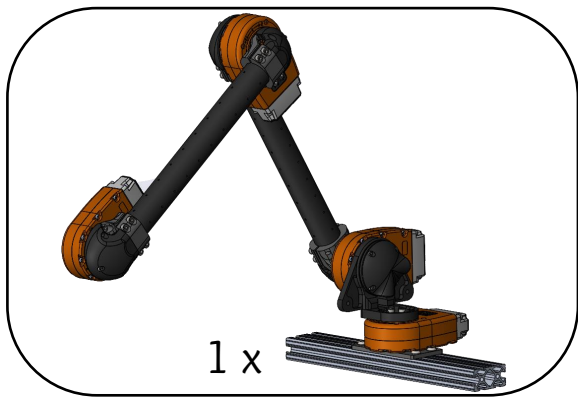

Install cables before adding caps

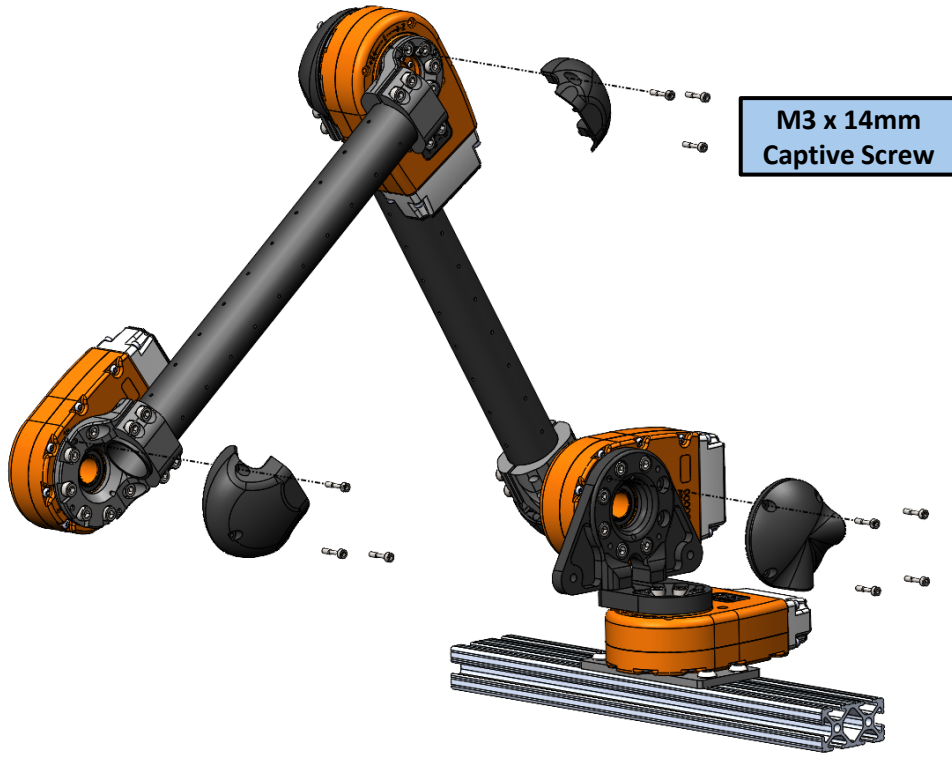

# All axes at zero degrees

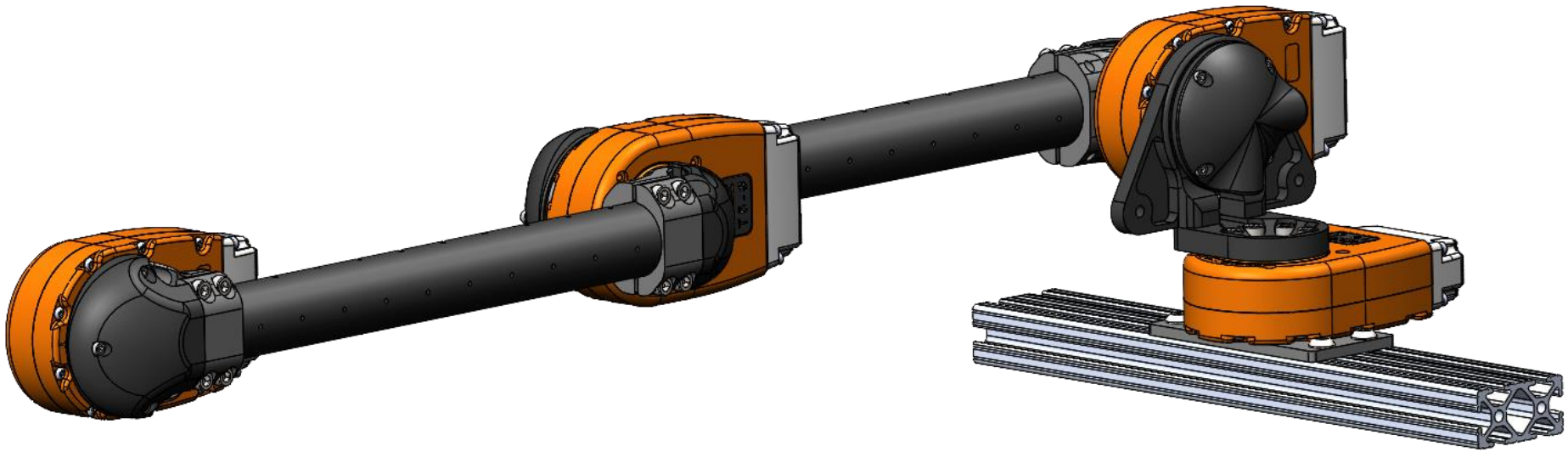

# Additional Accessories

- Power Supply, 36V 220W (A-2098-36)
  - Comes with correct Molex Minifit Jr 2 connector
  
- HEBI I/O Board (A-2116-01)
  - Integrate with 3<sup>rd</sup> party end effectors or tools using HEBI APIs



# HEBI

## ROBOTICS