

X- Series Gripper

Add-on to existing HEBI Kits.

Spool Module	Max Finger Torque	Max Finger Force at 50mm
X5-1	0.1 Nm	2 N
X5-4	0.5 Nm	10 N
X5-9	1.1 Nm	23 N
X8-3	0.4 Nm	8 N
X8-9	1.1 Nm	23 N
X8-16	2.0 Nm	40 N

Values assume symmetric two-finger grasp
End Effector Weight W/O Actuator: 0.22kg

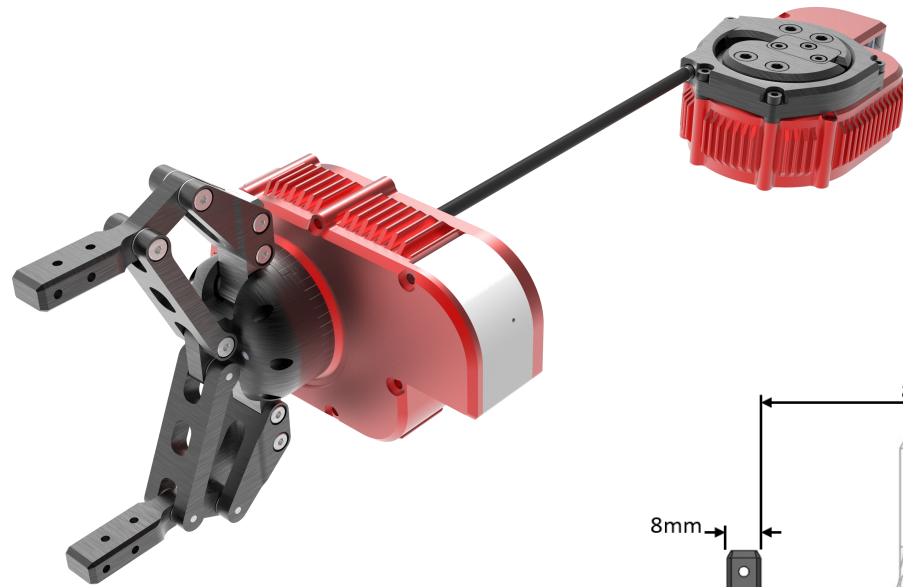

Suggested Actuator →

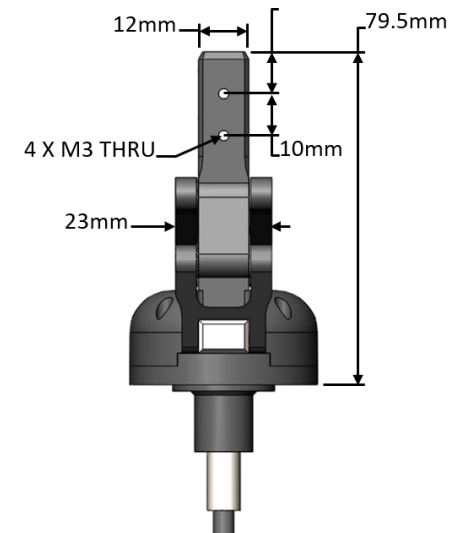
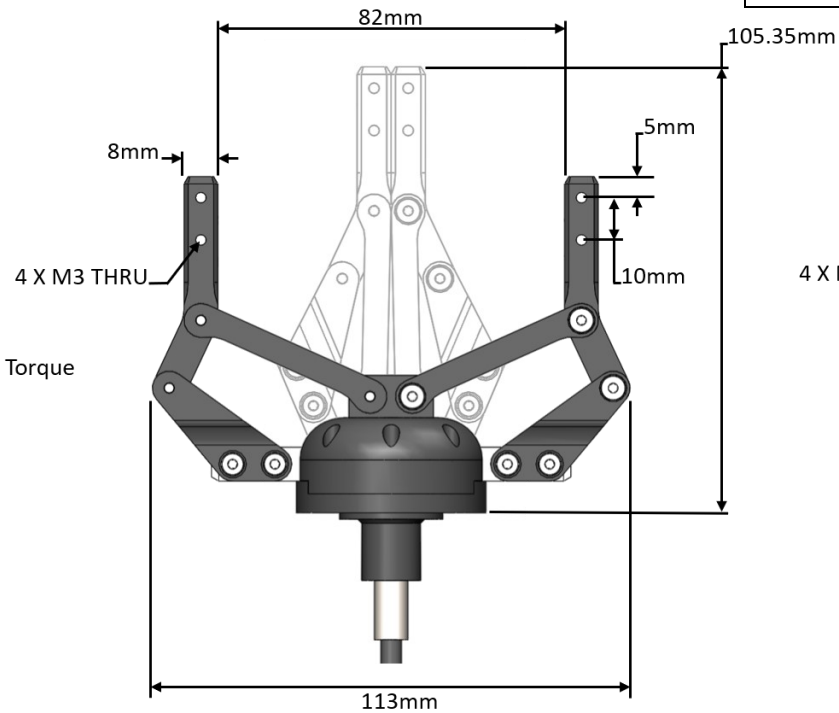
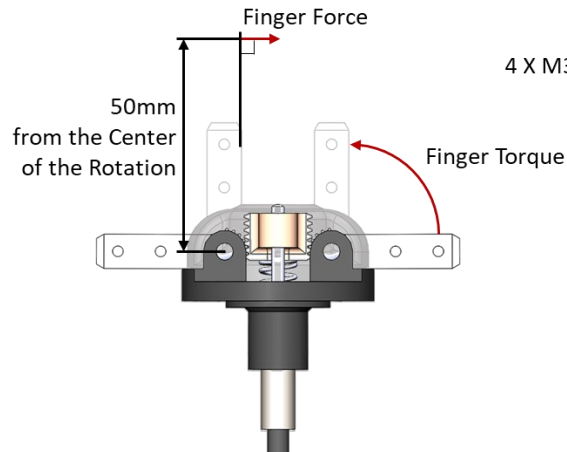

Request a quote at www.hebirobotics.com