

REVISIONS			
REV.	DESCRIPTION	DATE	APPROVED
A.01	INITIAL DRAFTING AND LAYOUT.	29 APR 2019	H KIM

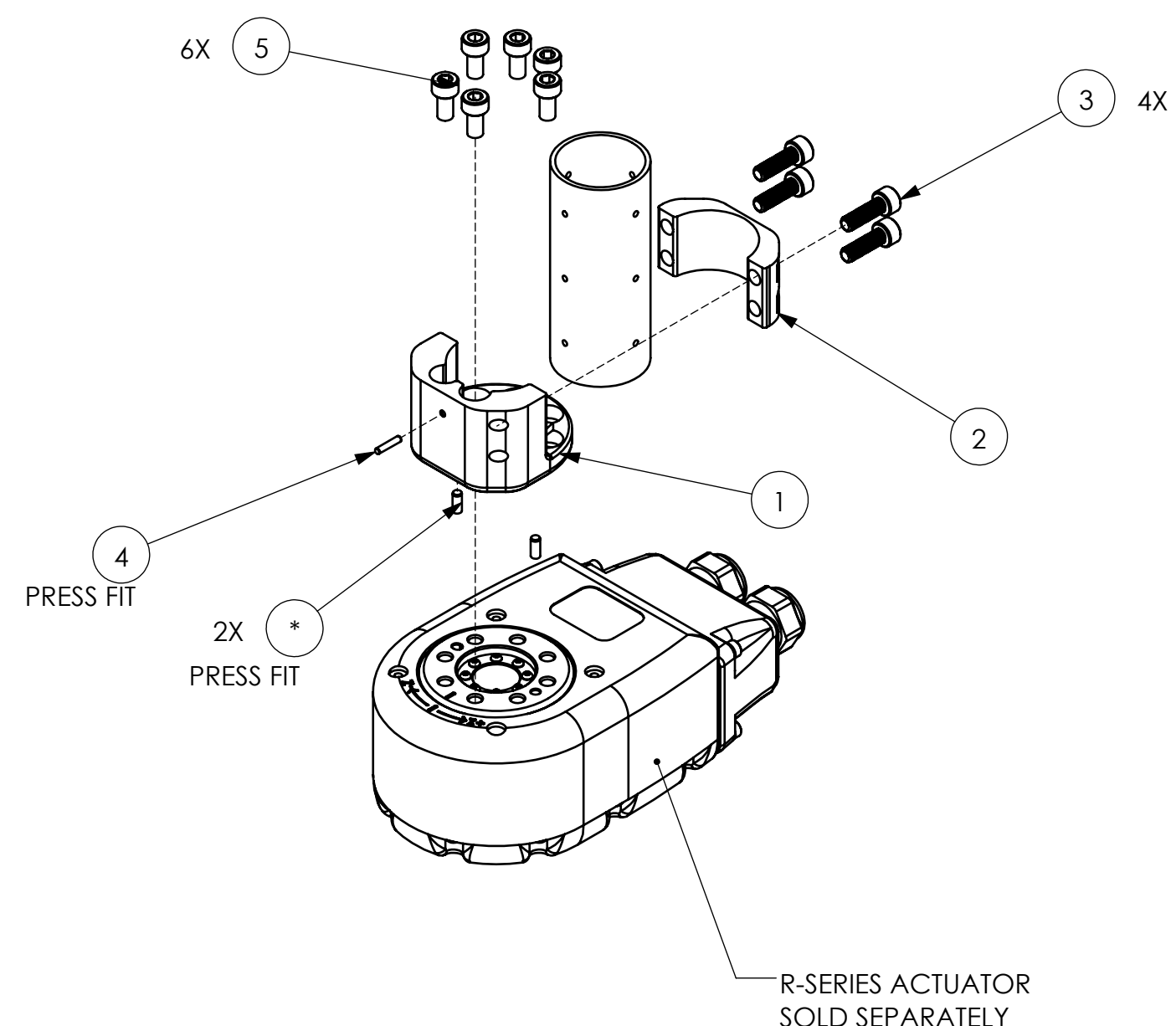

NOTE: TOTAL WEIGHT EXCLUDES R-SERIES ACTUATORS (SEE CONFIGURATION ON SHEET 2)

ITEM NO.	PART NUMBER	DESCRIPTION	Default/ QTY.
1	PM-2282-02	Output In-Line Tube Adapter	1
2	PM-2148-02	Tube Clamp	1
3	PP-2410-16	M5 SHCS, 16mm Length, Stainless Steel	4
4	PP-2136-10	M2 Dowel Pin, 10mm Length, Stainless Steel	1
5	PP-2410-10	M5 SHCS, 10mm Length, Stainless Steel	6
6	PP-2452-08	M3 Dowel Pin, 8mm Length, Stainless Steel	2

AUTHORIZATION		HEBI ROBOTICS, INC.	
DFTG:	H KIM	11 APR 2019	91 43rd St, Suite 200 Pittsburgh, PA 15201
DSGNR:	H KIM	11 APR 2019	PROJECT: R-Series Accessories
CHKR:			Output In-Line Tube Adapter
ENGR:			
UNLESS OTHERWISE SPECIFIED DIMENSIONS ARE IN MM DO NOT SCALE DRAWING			
TOLERANCES:	X.X	±.30	SIZE B
	X.XX	±.08	A-2225-01
	ANGLES	±1.00°	REV A.01
SCALE:	1:2	WEIGHT: 92.387 G	SHEET 1 OF 2
FILE NAME: A-2225-01.SLDDRW			

THE INFORMATION CONTAINED IN THIS DRAWING IS THE SOLE PROPERTY OF HEBI ROBOTICS, INC. ANY REPRODUCTION IN PART OR WHOLE WITHOUT WRITTEN PERMISSION OF IS PROHIBITED.

6 5 4 3 2 1

D
C
B
A

D
C
B
A

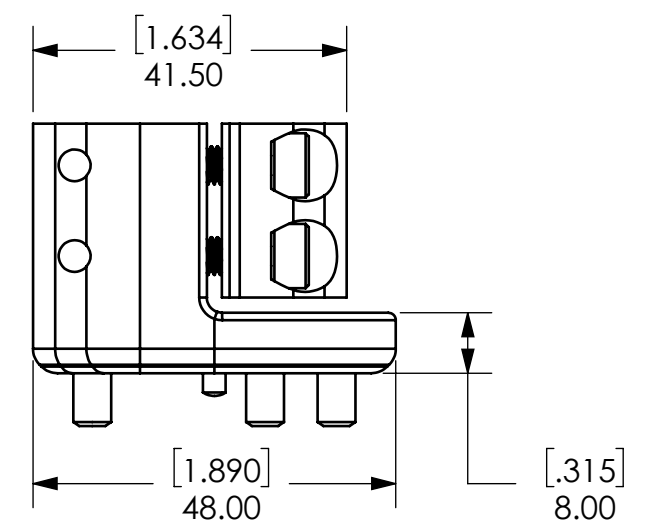
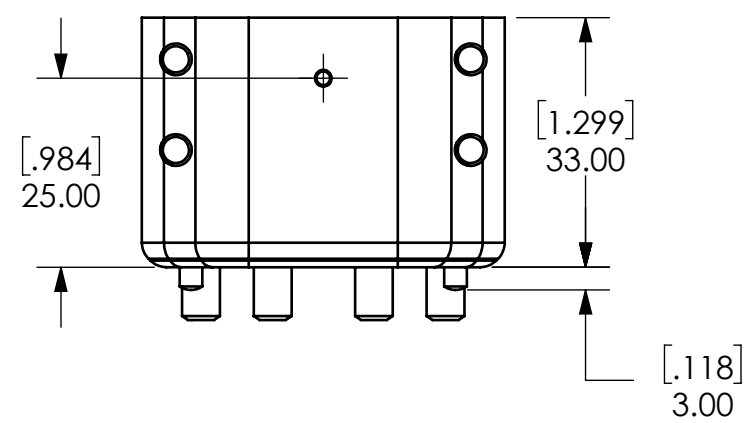
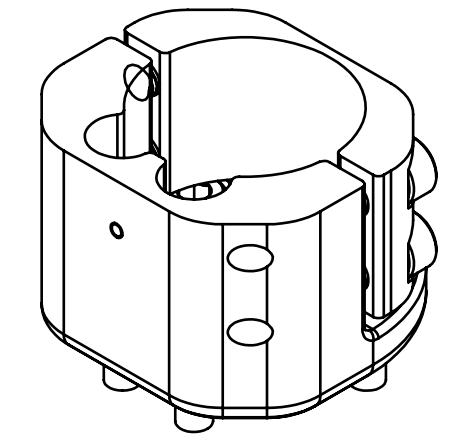
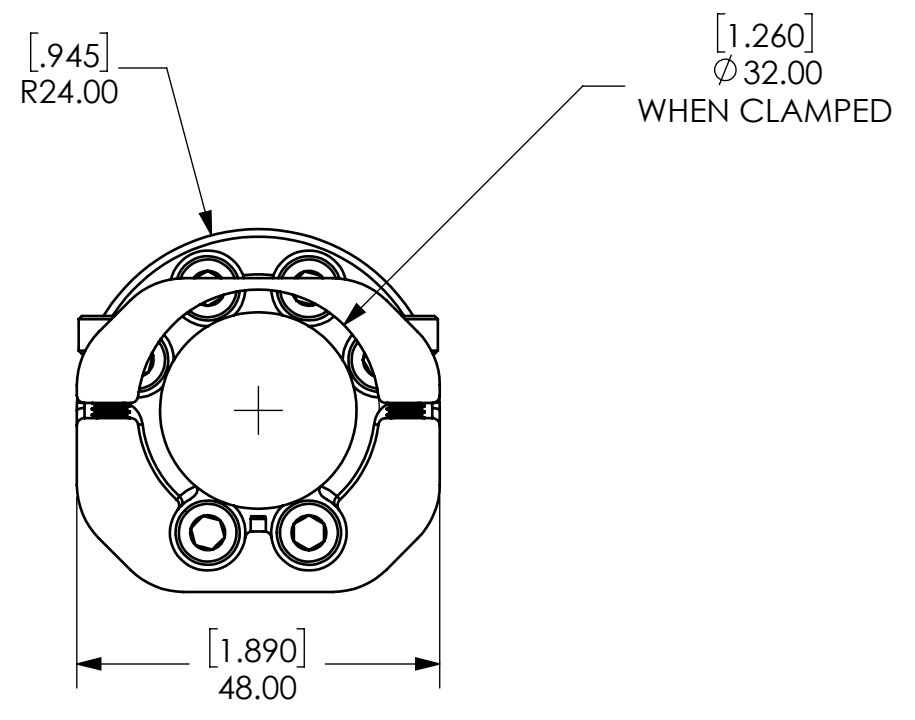

THE INFORMATION CONTAINED IN THIS DRAWING IS THE SOLE PROPERTY OF
HEBI ROBOTICS, INC. ANY REPRODUCTION IN PART OR WHOLE WITHOUT
WRITTEN PERMISSION IS PROHIBITED.

HEBI ROBOTICS, INC.
91 43rd Street, Suite 200
Pittsburgh, PA 15201

SIZE B	A-2225-01	REV A.01	VER
SCALE: 1:1	SHEET 2 OF 2		

6 5 4 3 2 1