

REVISIONS			
REV.	DESCRIPTION	DATE	APPROVED
A.01	INITIAL DRAFTING AND LAYOUT.	21 DEC 2017	A WILLIG

D
C
B
A

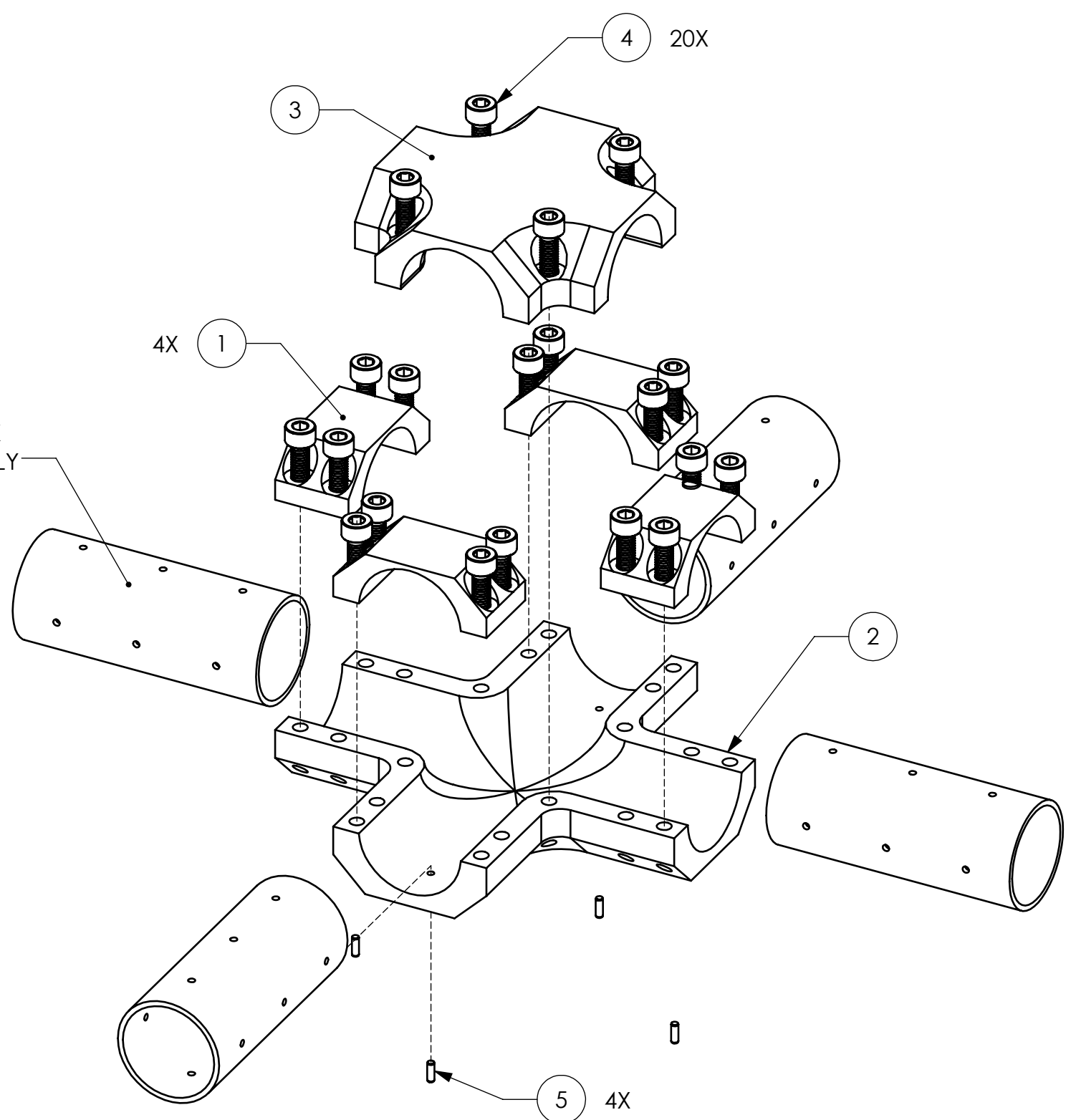

ITEM	PART NUMBER	DESCRIPTION	QTY
1	PM-2148-01	Tube Clamp	4
2	PM-2332-01	Tube-to-Tube Plus-Adapter	1
3	PM-2333-01	Tube-to-Tube Plus-Adapter Cover	1
4	PP-2131-16	M5 SHCS, 16mm Length, Steel	20
5	PP-2136-06	M2 Dowel Pin, 6mm Length, SS	4

NOTE: TOTAL WEIGHT EXCLUDES TUBES (SEE CONFIGURATION ON PAGE 2)

THE INFORMATION CONTAINED IN THIS DRAWING IS THE SOLE PROPERTY OF HEBI ROBOTICS, INC. ANY REPRODUCTION IN PART OR WHOLE WITHOUT WRITTEN PERMISSION OF IS PROHIBITED.

AUTHORIZATION		HEBI ROBOTICS, INC.	
DFTG: A WILLIG	DEC 2017	91 43rd St, Suite 200 Pittsburgh, PA 15201	
DSGMR: A WILLIG	DEC 2017	PROJECT: X-Series Accessories	
CHKR:		Tube-to-Tube Plus-Adapter	
ENGR:			
UNLESS OTHERWISE SPECIFIED DIMENSIONS ARE IN MM DO NOT SCALE DRAWING			
TOLERANCES:		X.X ±.30	REV VER
		X.XX ±.08	B A-2129-01 A.01
		ANGLES ±1.00°	SCALE: 1:1.5 WEIGHT: 463.718 G SHEET 1 OF 2
FILE NAME: A-2129-01.SLDDRW			

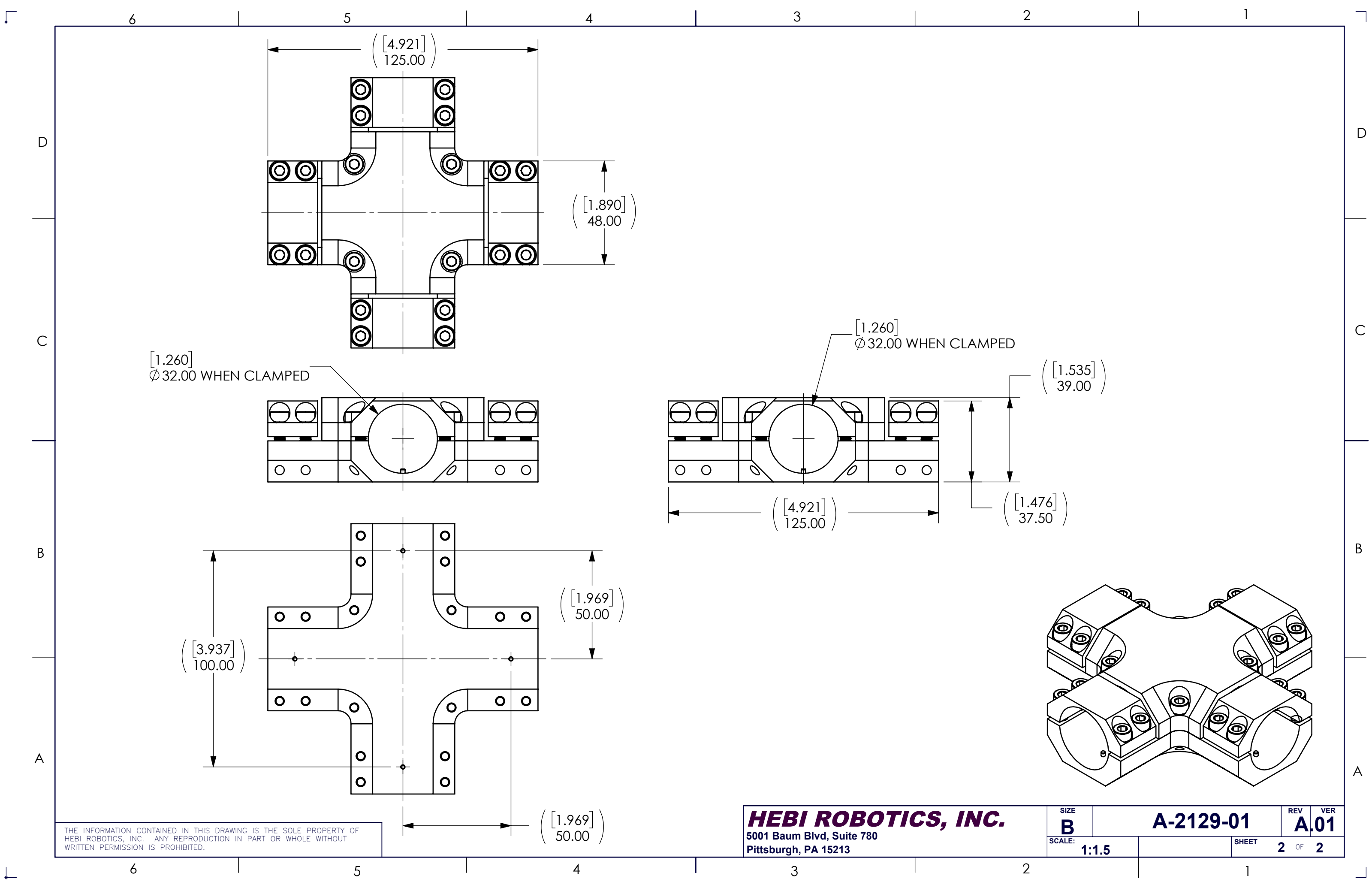

THE INFORMATION CONTAINED IN THIS DRAWING IS THE SOLE PROPERTY OF HEBI ROBOTICS, INC. ANY REPRODUCTION IN PART OR WHOLE WITHOUT WRITTEN PERMISSION IS PROHIBITED.

HEBI ROBOTICS, INC.
 5001 Baum Blvd, Suite 780
 Pittsburgh, PA 15213

SIZE B	A-2129-01	REV A.01	VER
SCALE: 1:1.5	SHEET 2	OF	2