

6 5 4 3 2 1

REVISIONS			
REV.	DESCRIPTION	DATE	APPROVED
A.01	INITIAL DRAFTING AND LAYOUT.	5 SEP 2017	A WILLIG

D
C
B
A

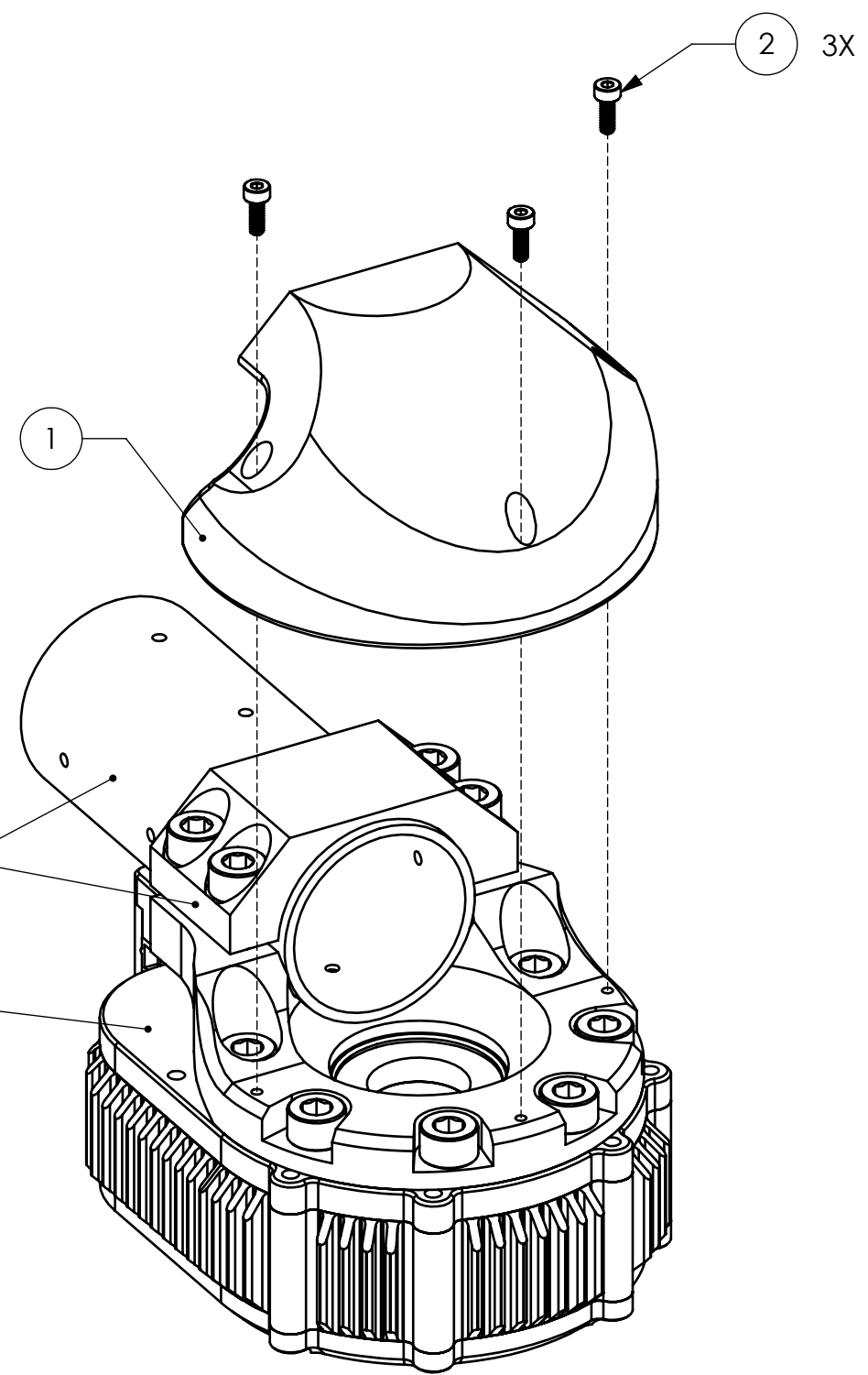

NOTE: TOTAL WEIGHT INCLUDES ONLY ITEMS IN BOM.

ITEM	PART NUMBER	DESCRIPTION	QTY
1	PM-2197-01	Input Mount Cover	1
2	PP-2133-08	M2 SHCS, 8mm Length, Steel	3

AUTHORIZATION		HEBI ROBOTICS, INC.	
DFTG: A Willig	5 Sep 2017	91 43rd St, Suite 200 Pittsburgh, PA 15201	
DSGMR: H Kim	Dec 2016	PROJECT: X-Series Accessories	
CHKR:		Input Tube Adapter Cover	
ENGR:			
UNLESS OTHERWISE SPECIFIED DIMENSIONS ARE IN MM DO NOT SCALE DRAWING			
TOLERANCES:		X.X ±.30	REV VER
		X.XX ±.08	B A-2091-01 A.01
		ANGLES ±1.00°	SCALE: 1:1 WEIGHT: 11.778 G SHEET 1 OF 1
FILE NAME: A-2091-01.SLDDRW			

THE INFORMATION CONTAINED IN THIS DRAWING IS THE SOLE PROPERTY OF HEBI ROBOTICS, INC. ANY REPRODUCTION IN PART OR WHOLE WITHOUT WRITTEN PERMISSION OF IS PROHIBITED.

6 5 4 3 2 1